

**Modicon  
Remote I/O Cable  
System Planning and Installation Guide**

890 USE 101 00

Version 2.0

**August 2001**



Schneider Electric  
One High Street  
North Andover, MA 01845

## Preface

The data and illustrations found in this book are not binding. We reserve the right to modify our products in line with our policy of continuous product improvement. Information in this document is subject to change without notice and should not be construed as a commitment by Schneider Electric. Schneider Electric assumes no responsibility for any errors that may appear in this document.

No part of this document may be reproduced in any form or by any means, electronic or mechanical, without the express written permission of Schneider Electric. All rights reserved.

The following are trademarks of Schneider Electric:

Modbus            Modbus Plus  
Modbus II        Quantum Automation Series  
984

MODSOFT® is a registered trademark of Schneider Electric.

IBM® is a registered trademark of International Business Machines Corporation. IBM AT™, IBM XT™, Micro Channel™, Personal System/2™, and NetBIOS™ are trademarks of International Business Machines Corporation.

Microsoft® and MS-DOS® are registered trademarks of Microsoft Corporation.

Copyright © 2001 by Schneider Electric. All rights reserved.  
Printed in U. S. A.

## Scope of this Manual

This manual is intended for the design engineer, cable system installer, and network manager involved with a Modicon Remote I/O (RIO) network. The manual describes

- Design, installation, test, and maintenance procedures for the RIO network
- Required media hardware—e.g., cables, taps, connectors, fiber optic options, tools—and approved optional hardware for special situations and environments
- RIO communication processing devices used with the Quantum Automation Series CPUs and the 984 family of PLCs
- Recommended installation and maintenance tests for the RIO network

## Objectives

This manual can be used as a planning tool to assist the design team in making its preliminary decisions about RIO system requirements, as a system design aid, as a reference for the cable system installation, and as a guide to testing and maintaining the network. It should be used in conjunction with the installation manuals for the particular PLC, RIO processing nodes (head-end processors and drop adapters), and I/O modules to be used in your system.

The discussions are hardware-related, with a detailed emphasis on the RIO network cable system. Programming and panel software issues are not discussed. For specific details related to hardware settings on the PLC, the I/O modules, and the processing nodes, refer to those modules' specific installation guides.

## How this Manual Is Organized

Chapter 1 is an overview of how an RIO network operates, listing the communication protocols, and key system hardware components.

Chapter 2 provides a series of illustrated cable topology models over which an RIO network may be implemented. In addition to standard linear, dual, and redundant cabling topologies, various optional approaches using Hot Standby

control modules and fiber optic repeaters are shown. It also presents some basic planning considerations such as:

- How to select appropriate installation environments
- Selection criteria for various cable media and other standard and optional hardware requirements
- Techniques for calculating attenuation on your cable system and for establishing suitable spacing between taps on the main (trunk) cable

Documentation templates are also provided to help you maintain a good record of your installation plan.

Chapter 3 lists the performance specifications for the cable types that have been approved for use on the 984 RIO network and describes in detail the various other required and optional hardware components that may be used in an RIO cable installation.

Chapter 4 provides descriptions of the various tasks required to install the RIO cable system.

Chapter 5 provides an overview of the test procedures that should be performed to verify the integrity of the cable installation and some troubleshooting suggestions for isolating problem sources on the network.

# Table of Contents

---

## Chapter 1 Remote I/O Networks—A Communications Overview . . . . . 1

1.1	RIO Network Communications . . . . .	2
	Data Transfer Consistency . . . . .	2
	Predictable Speeds for Time-critical Applications . . . . .	2
1.2	Processing Nodes on the RIO Network . . . . .	3
	RIO Processors . . . . .	3
	RIO Adapters . . . . .	4
1.3	RIO Network Communications . . . . .	6
	Setting Drop Addresses . . . . .	6
	How Messages Are Transmitted . . . . .	6
1.4	The RIO Network Cable System . . . . .	7
	Trunk Cable . . . . .	7
	Taps . . . . .	7
	Drop Cable . . . . .	7
	Terminating the Cable System . . . . .	7
1.5	Modicon Network Services . . . . .	9
1.6	RIO Network Node Part Numbers . . . . .	10

## Chapter 2 Planning and Designing an RIO Cable System . . . . . 11

2.1	Linear Cable Topologies . . . . .	12
	Standard Single-cable RIO Cable Systems . . . . .	12
	Redundant RIO Cable Systems . . . . .	13
	Dual Cable Systems . . . . .	14
2.2	Hot Standby Cable Topologies (for 984 PLCs) . . . . .	15
	Single-cable Hot Standby Systems . . . . .	15
	Redundant Hot Standby Cable Systems . . . . .	16
2.3	Illegal Coaxial Cable Topologies . . . . .	17
	Using a Splitter as a Branching Device . . . . .	17
	Illegal Trunk Cable Termination . . . . .	18
	Open Taps . . . . .	18
	Illegal Trunk Cable Connections . . . . .	19
	Illegal Drop Cable Connections . . . . .	19
2.4	Using Fiber Optics in an RIO System . . . . .	20
	Point-to-point Topology with Fiber Optics . . . . .	20
	Bus Topology with Fiber Optics . . . . .	22
	Star and Tree Topologies with Fiber Optics . . . . .	23
	Self-healing Ring Fiber Optic Topology . . . . .	25
2.5	RIO System Design . . . . .	26

	Key Elements in a Cable System Plan .....	26
	Planning for System Expansion .....	27
2.6	Choosing Coaxial Cables for an RIO Network .....	28
	Coaxial Cable Construction .....	28
	Flexible Cable .....	29
	Semirigid Cable .....	29
2.7	Coaxial Cable Characteristics .....	30
	Cable Bend Radius .....	30
	Cable Support .....	30
	Cable Pull Strength .....	30
	Environmental Considerations .....	30
2.8	Electrical Characteristics of Coaxial Media Components .....	32
	Impedance .....	32
	Attenuation .....	32
	Return Loss .....	33
2.9	EMI/RFI Considerations in a Coaxial Cable Routing Plan .....	34
	Guidelines for Interference Avoidance .....	34
2.10	Tap Connections and Locations .....	35
	Using Band Marked Trunk Cable .....	35
	Tap Port Connections .....	35
	Optional Tap Enclosure Considerations .....	36
2.11	Grounding and Surge Suppression .....	37
	Earth Ground .....	37
	Lightning Protection for RIO Cable Systems .....	37
2.12	Terminating a Coaxial Cable System .....	38
	Terminating the Trunk Cable .....	38
	Terminating Unused Tap Ports .....	38
	Terminating the Drops .....	38
2.13	Designing a Coaxial Cable System to an Attenuation Limit .....	39
	Cable Attenuation .....	39
	Tap Attenuation .....	39
	Calculating Maximum System Attenuation .....	40
	Calculating Attenuation on a Coaxial Network—An Example .....	40
2.14	Calculating Attenuation on an Optical Path .....	43
	Minimum Distance between Repeaters .....	43
	Example—Attenuation on a Simple Optical Link .....	44
	Example—An Optical Link with a Star Coupler .....	45
2.15	Pulse Width Distortion in a Fiber Optic Bus Topology .....	46
	Example—Calculating Repeaters on a 10 km Optical Path .....	46
2.16	Planning RIO Drops .....	48
	Connecting the Drop Cable to the Drop Adapter .....	48
	Minimizing Low Receive Signal Level Problems .....	49
	Documenting Your Cable System Design .....	49

**Chapter 3 RIO Network Hardware Components . . . . . 53**

- 3.1 RG-6 Cable . . . . . 54
  - Modicon RG-6 Cable . . . . . 54
  - Other Approved RG-6 Cables . . . . . 55
  - Approved RG-6 Plenum Cable . . . . . 56
- 3.2 RG-11 Cable . . . . . 57
  - Modicon RG-11 Cable . . . . . 57
  - Other Approved RG-11 Cables . . . . . 57
  - Approved RG-11 Armored and Plenum Cables . . . . . 60
- 3.3 Approved Semirigid Cables . . . . . 61
- 3.4 Selecting Fiber Optic Cable . . . . . 65
- 3.5 Hardware Overview . . . . . 66
  - Required Cable System Hardware Components . . . . . 66
  - Optional Cable System Hardware Components . . . . . 66
  - The Optional RIO Fiber Optics Repeater . . . . . 66
  - RIO System Hardware Components . . . . . 67
- 3.6 Tap Specifications . . . . . 68
- 3.7 Splitter Specifications . . . . . 70
- 3.8 F Connectors for Coaxial Cables . . . . . 72
  - F Connectors for Quad Shield RG-6 Cable . . . . . 72
  - F Connectors for Non-quad Shield RG-6 Cable . . . . . 72
  - F Connectors for RG-11 Cable . . . . . 73
- 3.9 F Adapters for Semirigid Cable . . . . . 74
- 3.10 BNC Connectors and Adapters . . . . . 75
  - BNC Connectors for RG-6 Cable . . . . . 75
  - F-to-BNC Adapters for RG-11 Cable . . . . . 75
  - BNC Jack to Male F Connector . . . . . 76
- 3.11 Network Terminators . . . . . 77
  - Tap Port Terminators . . . . . 77
  - Trunk Terminators . . . . . 77
  - BNC In-line Terminators . . . . . 78
  - Self-terminating BNC Adapters for Hot Standby Systems . . . . . 78
  - Warning Labels . . . . . 79
- 3.12 Self-terminating F Adapter Options . . . . . 80
  - Self-terminating F Adapters . . . . . 80
  - Warning Labels . . . . . 81
- 3.13 Ground Blocks . . . . . 82
- 3.14 Surge Suppressors . . . . . 83
- 3.15 Cable Waterproofing Materials . . . . . 84
- 3.16 Fiber Optic Repeater . . . . . 85
  - Repeater Indicator LEDs . . . . . 86
  - RIO Shield-to-Chassis Jumper . . . . . 86
- 3.17 Recommended Materials for Fiber Optic Links . . . . . 88
  - Connectors . . . . . 88

Termination Kits .....	88
Passive Couplers .....	88
Other Tools .....	89
<b>Chapter 4 Installing an RIO Network .....</b>	<b>91</b>
4.1 Installation Overview .....	92
4.2 RG-6 Cable Connections .....	93
Installation Tools .....	93
4.3 RG-6 Installation Tools .....	94
RG-6 Cable Installation Tool .....	94
Crimp Tool .....	95
Cable Cutters .....	95
4.4 Preparing RG-6 Cable for a Connector .....	96
4.5 Installing F Connectors on Quad Shield RG-6 Cable .....	98
4.6 Installing F Connectors on Non-quad Shield RG-6 Cable .....	101
4.7 Installing BNC or Self-terminating F Connectors on RG-6 Cable .....	103
4.8 Making RG-11 F Connections .....	105
Required Tools .....	105
4.9 The RG-11 Installation Tool .....	106
4.10 Preparing an RG-11 Cable for a Connector .....	107
4.11 Installing F Connectors on RG-11 Cable .....	109
4.12 Providing Line Termination on the Drop Cable .....	112
Installing a BNC In-line Terminator on a Drop Cable .....	112
Optional Drop Cable In-line Termination .....	113
4.13 Connecting/Disconnecting a Drop Cable at a Tap .....	114
4.14 Installing Fiber Optic Repeaters .....	116
Mounting a Repeater .....	116
Connecting the Network Cables .....	117
RIO Shield-to-Chassis Jumper .....	117
Connecting Power .....	117
4.15 Terminating the Trunk Cable .....	120
4.16 Installing the Ground Point .....	121
<b>Chapter 5 Testing and Maintaining an RIO Network .....</b>	<b>123</b>
5.1 Maintenance and Testing Requirements .....	124
Documenting Drop Maintenance Information .....	124
5.2 RIO System Tests .....	126
Fundamental RIO System Tests .....	126
RIO System Tests for Critical Applications .....	127
Network Startup .....	128



5.3	Problem Sources on an RIO Network .....	129
	Solving Spacing Problems .....	129
	Potential Grounding Problems .....	129
	Problems Stemming from Poor Installation .....	130
5.4	On-line and Off-line Error Isolation .....	131
5.5	Troubleshooting Fiber Optic Repeaters .....	132
	Broken Cable Detection and Remedies .....	133
 <b>Appendix A RIO Cable Material Suppliers .....</b>		<b>135</b>
 <b>Appendix B Glossary .....</b>		<b>137</b>
 <b>Index .....</b>		<b>145</b>

# Chapter 1

## Remote I/O Networks: A Communications Overview

---

- RIO Network Communications
- Processing Nodes on the RIO Network
- RIO Network Communications
- The RIO Network Cable System
- Modicon Network Services
- RIO Network Node Part Numbers

## 1.1 RIO Network Communications

---

Modicon's RIO network is a high speed (1.544 Mbit/s) local area network (LAN) that uses commercially available coaxial cable and CATV media technology. RIO supports:

- Discrete and register data to input and output module communications
- ASCII message transmissions to and from certain RIO drop adapters

### 1.1.1 Data Transfer Consistency

An RIO network provides high speed data transfer. Most data transfers between the RIO processor (at the PLC head-end) and the RIO adapters (at the remote drops) take less than 1 ms for one drop of I/O.

PLCs service their drop adapters only at the end of logic segments. Multiple logic segments may be serviced in one scan. Updating RIO data at the end of segment ensures consistent data throughput. A (CRC16) message frame check assures that RIO messages will arrive reliably and completely error-checked at the proper destination node

### 1.1.2 Predictable Speeds for Time-critical Applications

As a high speed LAN, RIO must support applications that are very time-critical. In this respect, RIO has several advantages over other proprietary PLC communication methods:

- Its HDLC protocol implementation makes the RIO data transfer speed very predictable
- The PLC services each node using a consistent communications method—the I/O drops are always updated in a determinate time period that can be calculated based on the number of segments in the user logic program
- Only one node transmits at a given time, so message collisions do not occur—each node is able to transmit on the network in a determinate time period
- RIO has high data integrity due to the frame check sequence and error checking at the physical protocol layer

## 1.2 Processing Nodes on the RIO Network

---

The RIO network supports communications between a PLC and one or more drops of I/O modules dispersed throughout your local area—e.g., your manufacturing or processing facility. All messages on the RIO network are initiated by a master node called the *RIO head* or *processor*. All other nodes on the network communicate with the RIO head via *RIO adapters* located at the drops. The network is proprietary, and Modicon processing nodes must be used throughout the RIO network.

### 1.2.1 RIO Processors

RIO is fundamentally a single-master network, and the RIO processor is the master node. The RIO processor is located at the PLC at the head-end of the RIO network. Depending on the type of PLC you are using, the RIO processor can be implemented in hardware as an option module that mounts beside the PLC or as a board built into the PLC.

The S908 RIO processor handles the remote I/O communication protocol supported by the Modicon's PLC families. All 984 PLCs that support remote I/O and all Quantum Automation Series PLCs use the S908 protocol.

PLC Type	Hardware	Dynamic Range	Max. RIO Drops
984A	S908 chassis module	35 dB	32
984B	S908 chassis module	35 dB	32
984X	On the S929 Processor	35 dB	6
AT-984	On host-based PLC card	32 dB	6
MC-984	On host-based PLC card	32 dB	6
Q-984	On host-based PLC card	32 dB	6
984-485E/K	S908 slot mount module	35 dB	6
984-685E	S908 slot mount module with AS-E908-016 Executive	35 dB	15
	S908 slot mount module with AS-E908-131 Executive	35 dB	31
984-785E/K/D	S908 slot mount module with AS-E908-016 Executive	35 dB	15
	S908 slot mount module with AS-E908-131 Executive	35 dB	31
140 CPU 113 02	140 CRP 931 or 140 CRP 932 Quantum module	35 dB	31
140 CPU 113 03			
140 CPU 213 04			

### 1.2.2 RIO Adapters

An adapter module resides at each remote drop on the RIO network. The type of adapter used depends on:

- The type of RIO processor at the head-end of the network
- The series of I/O modules at the drop
- Whether or not ASCII devices are being supported at the drop
- Whether the drop adapter will support one or two RIO cables

Drop Adapter	Head Processor	I/O at the Drop	ASCII Ports	RIO Cable Ports
140 CRA 931 00	140 CRP 931 00	Quantum	N/A	1
140 CRA 932 00	140 CRP 932 00	Quantum	N/A	2
AS-J890-101	S908	800	0	1
AS-J890-102	S908	800	0	2
AS-J892-101	S908	800	2	1
AS-J892-102	S908	800	2	2
AS-P890-000	S908	800	0	1
AS-P892-000	S908	800	2	1

### Field Adapter Kits

Field adapter kits are also available to convert the P451 and most P453 Adapters to the S908 RIO protocol. This conversion allows the Quantum CPUs, the 984E controllers, and the host-based CPUs to support installed drops of 200 Series I/O.

Kit	New RIO Adapter	RIO Ports	ASCII Ports	Power Supply
AS-J290-010	AS-P453-581	1	0	50 Hz
	AS-P453-681	1	0	60 Hz
	AS-P453-582	1	2	50 Hz
	AS-P453-682	1	2	60 Hz
AS-J290-020	AS-P453-591	2	0	50 Hz
	AS-P453-691	2	0	60 Hz
	AS-P453-592	2	2	50 Hz
	AS-P453-692	2	2	60 Hz
AS-J291-010	AS-P451-581	1	0	50 Hz
	AS-P451-681	1	0	60 Hz

## 1.3 RIO Network Communications

---

Each RIO drop adapter on the network must be assigned a unique address number. The RIO processor uses this *drop address* to send I/O module data or ASCII message data to the proper adapter. The physical location of an adapter on the network has no bearing on its address or on the data throughput, making the RIO network a true bus architecture.

### 1.3.1 Setting Drop Addresses

RIO drop adapters have switches on them that are used to set the unique RIO drop address and ASCII port addresses (if ASCII devices are supported at the drops). DIP switches are used on the 984 type adapters, and rotary switches are used on Quantum adapters. Consult the hardware documentation for location of the switches and appropriate settings.

### 1.3.2 How Messages Are Transmitted

A message initiated by the RIO head processor travels along the network's cable system and is received by all RIO adapters. The RIO adapter with the address specified in the message can then transmit a response message back to the RIO head within a specific time period. If the drop adapter does not respond, the same message is sent again. The process of resending the message after no response is called a *retry*.

If the adapter does not respond to several retries, the drop is declared dead. On each successive scan of the PLC, the RIO head attempts to re-establish communications with the adapter—only one attempt per scan will be made to communicate with a dead drop until the adapter is successfully brought back up.

## 1.4 The RIO Network Cable System

---

The RIO processor at the controller head-end is connected to an adapter at each of the remote drops via a network cable system.

### 1.4.1 Trunk Cable

Starting at the RIO processor and running the entire length of the network are one (linear) or two (dual or redundant) *trunk* cable(s). Taps are installed along the length of the trunk cable(s), and a drop cable is run from a tap to a drop adapter. The trunk cable may be an approved flexible or semirigid coaxial type, as specified in Chapter 3.

### 1.4.2 Taps

The taps connect the drop adapter at each drop to the trunk cable via a drop cable, providing each adapter with a portion of the signal that is on the trunk. The taps also isolate each drop adapter from all other drop adapters on the network so that they won't interfere with each other.

### 1.4.3 Drop Cable

Extending from a tap to an adapter is a *drop* cable. The drop cable connects to the tap with an F connector, and it connects to the adapter with either an F connector or a BNC connector, depending on the type of RIO adapter at the drop (see Section 2.16). The drop cable may be an approved coaxial type, as specified in Chapter 3.

### 1.4.4 Terminating the Cable System

A proper impedance match is maintained across the network with 75  $\Omega$  terminators. You must install a 75  $\Omega$  terminator:

- In the unused trunk port of the last tap on the network to terminate the trunk cable
- In any open drop cable ports on taps that have been installed for future system expansion
- In-line on cables running from the primary and standby controllers to the splitter in a Hot Standby system; this allows you to disconnect one of the two Hot Standby controllers while the other one maintains primary control



Terminators are present inside most drop adapters to automatically terminate each drop connection—the exceptions are some older J890/J892 Adapters and the 410 and 3240 Motion Control products:

---

**RIO Adapters that Do Not Have Internal Termination**

---

**RIO Drop Adapters**

AS-J890-001	AS-J892-001
AS-J890-002	AS-J890-002

**410 Motion Controllers**

110-230	110-231
110-232	110-233

**3240 Motion Controllers**

100-265-815
100-265-816
100-265-825

---

The devices listed above require an in-line terminator installed in the drop cable (the J890/J892-10x Adapters do contain in-line terminators).

When a drop cable (without in-line termination) gets disconnected from an adapter while the network is running, the possibility of network errors and data transfer delays is introduced. You may want to consider designing some form of mechanical termination into your drop cables—e.g., Modicon 60-0513-000 cable—particularly if a time-critical application is being run on the network. For more details on this and other aspects of cable system termination, see page 38.

## 1.5 RIO Network Node Part Numbers

RIO Device Type		One RIO Port	Two RIO Ports
Head Processor	in a 16K 984A chassis (standard)	Px-984A-816*	
	in a 32K 984A chassis (standard)	Px-984A-832*	Px-984A-932*
	in a 32K 984B chassis (standard)	Px-984B-832*	Px-984B-932*
	in a 64K 984B chassis (standard)	Px-984B-864*	Px-984B-964*
	in a 128K 984B chassis (standard)	Px-984B-828*	Px-984B-928*
	in a 984X chassis (standard)	S929-001	
	on an AT-984 (standard)	AM-0984-AT0	
	on an MC-984 (standard)	AM-0984-MC0	
	on a Q984 for MicroVAX II (standard)	AM-0984-Q20	
	on a 984-485E (standard)	PC-E984-485	
	on a 984-485K (standard)	PC-K984-485	
	option module for 984-685E and 984-785E/K/D	AS S908-110	AS-S908-120
	option module for Quantum all CPUs	140 CRP 931 00	140 CRP 932 00
Drop Adapter	for 800 Series I/O	AS-J890-101	AS-J890-102
	for 800 Series I/O with two ASCII ports	AS-J892-101	AS-J892-102
	for 800 Series I/O, with built-in P/S	AS-P890-000	
	for 800 Series I/O with ASCII, built in P/S	AS-P892-000	
	J291 conversion for 200 Series I/O	AS-P451-581/-681	
	J290 conversion for 200 Series I/O with ASCII	AS-P453-582/-682	AS-P453-592/-692
	without ASCII	AS-P453-581/-681	AS-P453-591/-691
	for Quantum I/O	140 CRA 931 00	140 CRA 932 00

\* These part numbers are for the entire chassis mount PLC system, including the chassis itself; x = 1 for a four-card chassis, and x = 5 for a seven card chassis.

# Chapter 2

## Planning and Designing an RIO Cable System

---

- Linear Cable Topologies
- Hot Standby Topologies
- Illegal Coaxial Cable Topologies
- Using Fiber Optics in an RIO System
- RIO System Design
- Choosing Coaxial Cables for an RIO Network
- Coaxial Cable Characteristics
- Electrical Characteristics of RIO Media Components
- EMI/RFI Considerations in a Coaxial Cable System Plan
- Tap connections and Locations
- Grounding and Surge Suppression
- Terminating a Coaxial Cable System
- Designing a Coaxial Cable System to an Attenuation Limit
- Calculating Attenuation on an Optical Path
- Pulse Width Distortion in a Fiber Optic Bus Topology
- Planning RIO Drops

## 2.1 Linear Cable Topologies

There are many possible topologies that may be used for RIO networks. The most common RIO networks use one or two coaxial trunk cables with taps that connect them via coaxial drop cables to a series of remote I/O drops. At the head-end of a trunk cable is the PLC with an RIO processor, and at each remote drop is an RIO adapter. These topologies are linear—they do not use any branches or loops in the cable layouts.

### 2.1.1 Standard Single-cable RIO Cable Systems

A single-cable linear topology is the simplest and most commonly used RIO cable system:

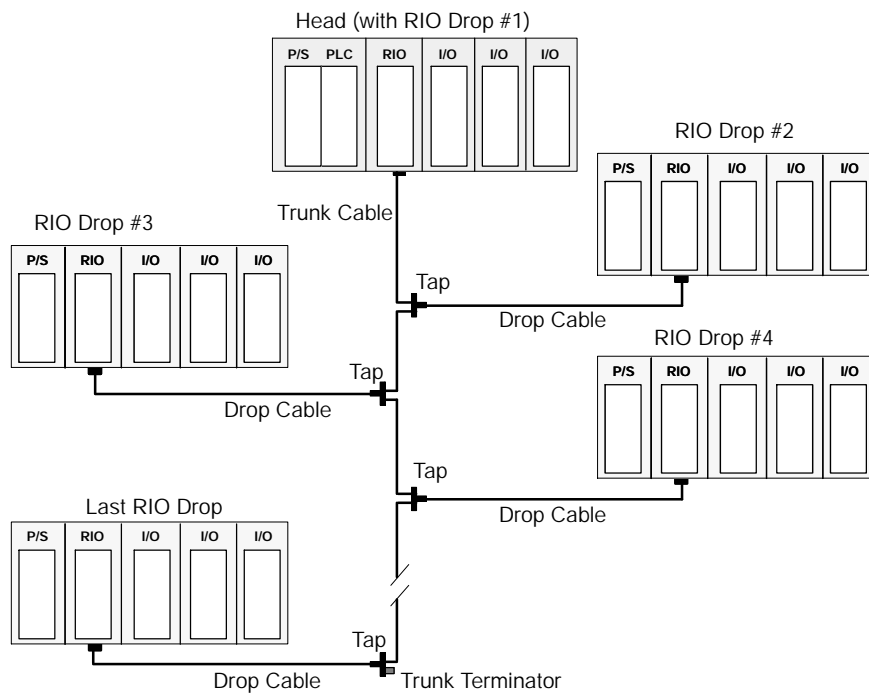

**Note** Because this example uses local I/O at the head, the first remote drop in the network will be I/O mapped as drop #2. If the PLC you are using does not support local I/O—e.g., the 984A/B PLCs—then the first drop in the I/O network will be I/O mapped as drop #1.

## 2.1.2 Redundant RIO Cable Systems

If both the head processor and the drop adapters have two cable ports, then redundant linear cables can be run. A redundant topology provides two parallel paths to the same remote I/O drops. It allows you to increase the communications integrity on an RIO network, allowing the network to operate even when one cable system is damaged or malfunctioning.

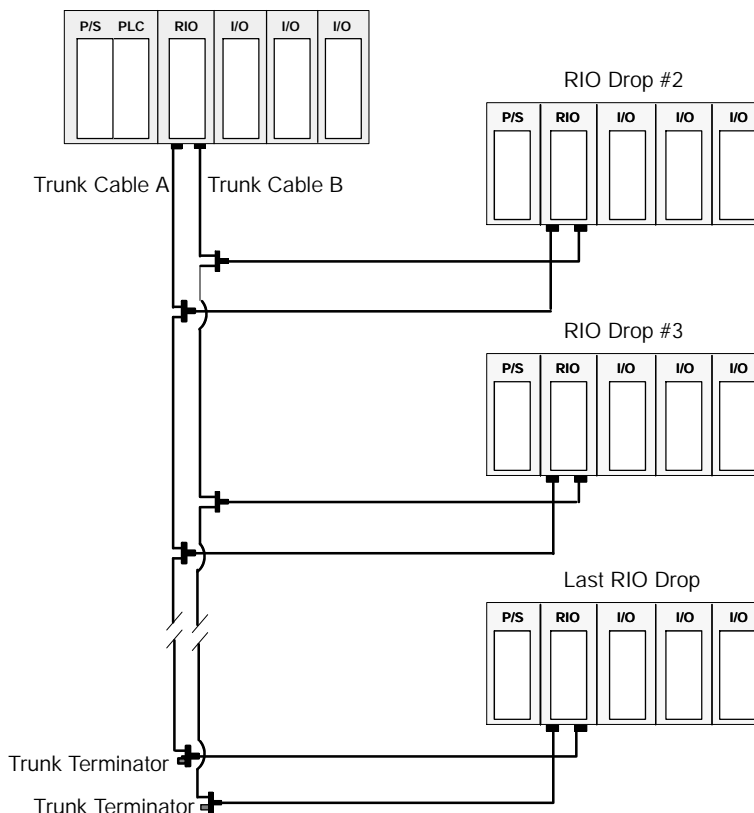

The two cables are treated as two separate networks, and each cable is an independent system running from the same RIO processor to the same remote I/O drops. If a break occurs in cable A or cable B, an LED goes ON at the RIO head processor. The condition is also logged in words 179 ... 277 of the status table; these status words can be accessed via the STAT instruction (see *Modicon Ladder Logic Block Library User Guide*, 840 USE 101 00).

A redundant cable topology requires two RIO cable ports on the RIO processor and on all the RIO drop adapters.

### 2.1.3 Dual Cable Systems

If your RIO processor has two cable ports, then two linear cables can be run along separate routes to different sets of remote drops. A dual cable system can be used to extend the total length of the cable system. This topology allows you to use the full dynamic range in both directions, thus allowing the cable system's total length to be extended. This topology requires a dual cable port at the RIO processor and a single cable port at each of the RIO drop adapters.

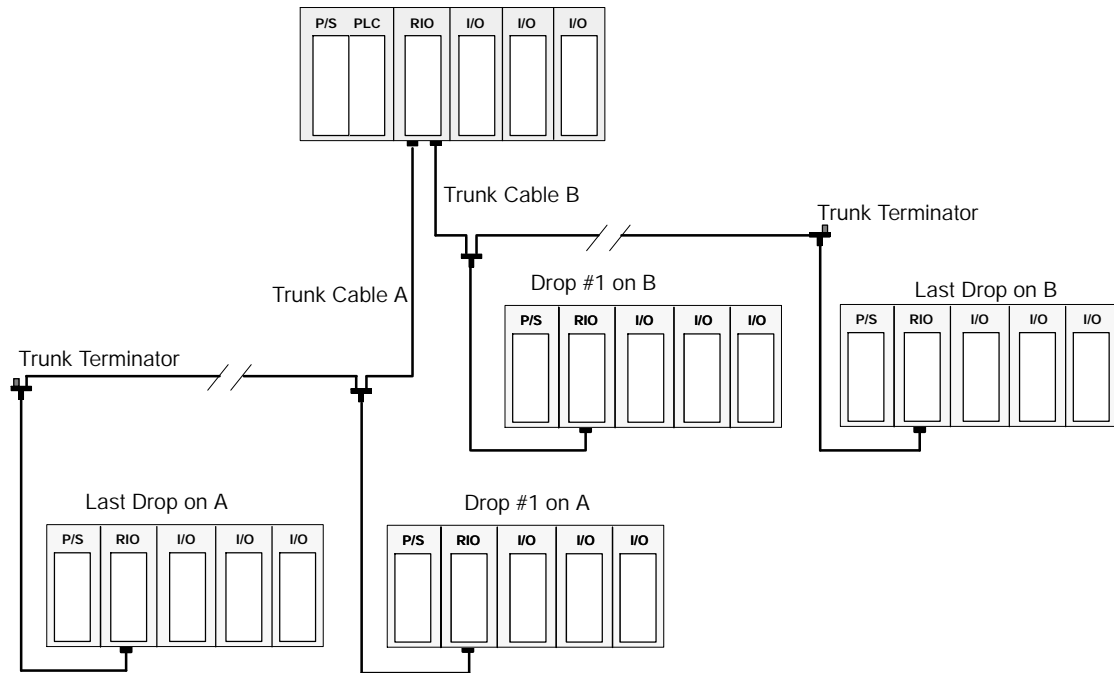

The lengths of the trunk cables and the number of drops from each do not need to be balanced in a dual cable system. In most respects, the two lines can be installed as if they were two independent cable systems, with two special considerations:

- The total number of drops on both lines must not exceed the maximum number of drops supported by the PLC
- Each drop on the two trunks must have a unique RIO network address



**Note** RIO statistics using the STAT block will not provide the true status of each drop because the drops will only be attached to one of the two RIO connectors at the head processor. Also, an error LED will be ON at the RIO processor.

## 2.2 Hot Standby Cable Topologies (for 984 PLCs)

A Hot Standby (HSBY) system comprises two identically configured PLC heads (with S908 RIO Processors and HSBY option modules) connected via a splitter so that they both support the same cable system. The splitter is used as a combiner. One of the PLCs acts as the *primary* controller (updated by the RIO network) while the other is the *standby* controller (updated by the HSBY option module). In the event that the primary PLC fails, control responsibilities are switched over to the standby device.

 **Note** The Hot Standby capability is supported only in the 984 PLCs. The primary and standby heads both use an HSBY option module.

### 2.2.1 Single-cable Hot Standby Systems

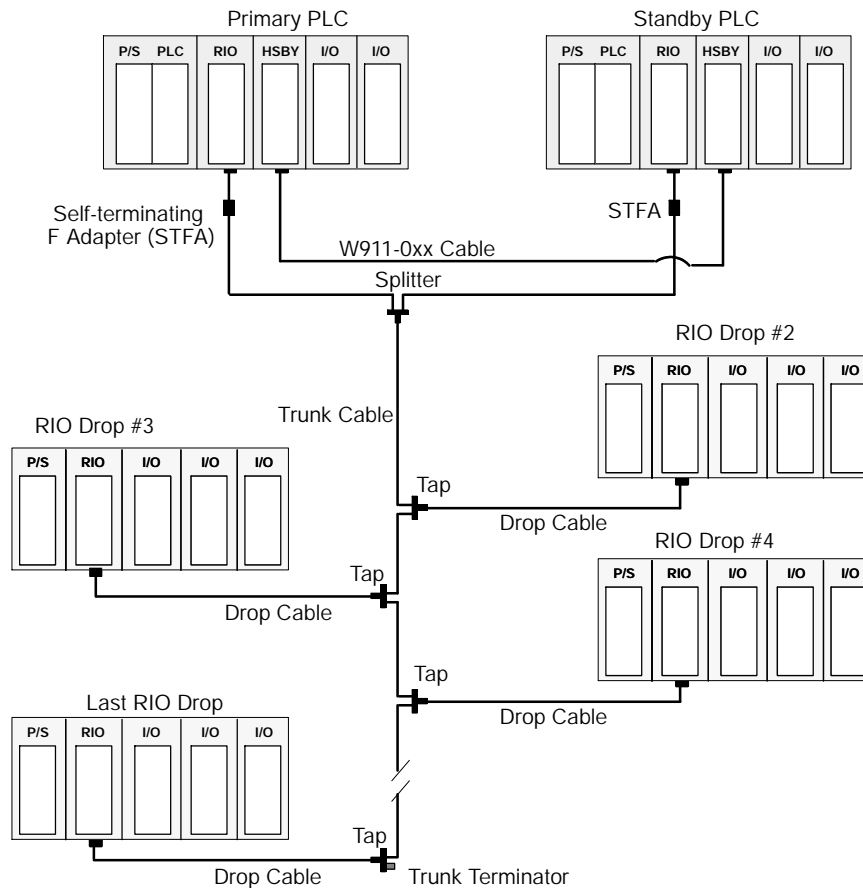

## 2.2.2 Redundant Hot Standby Cable Systems

Using redundant cabling in a Hot Standby system creates a very powerful system with backup both at the controller head-end and along the RIO network. This topology requires the use of RIO head processors and drop adapters with two RIO cable ports, and it requires the use of two splitters.

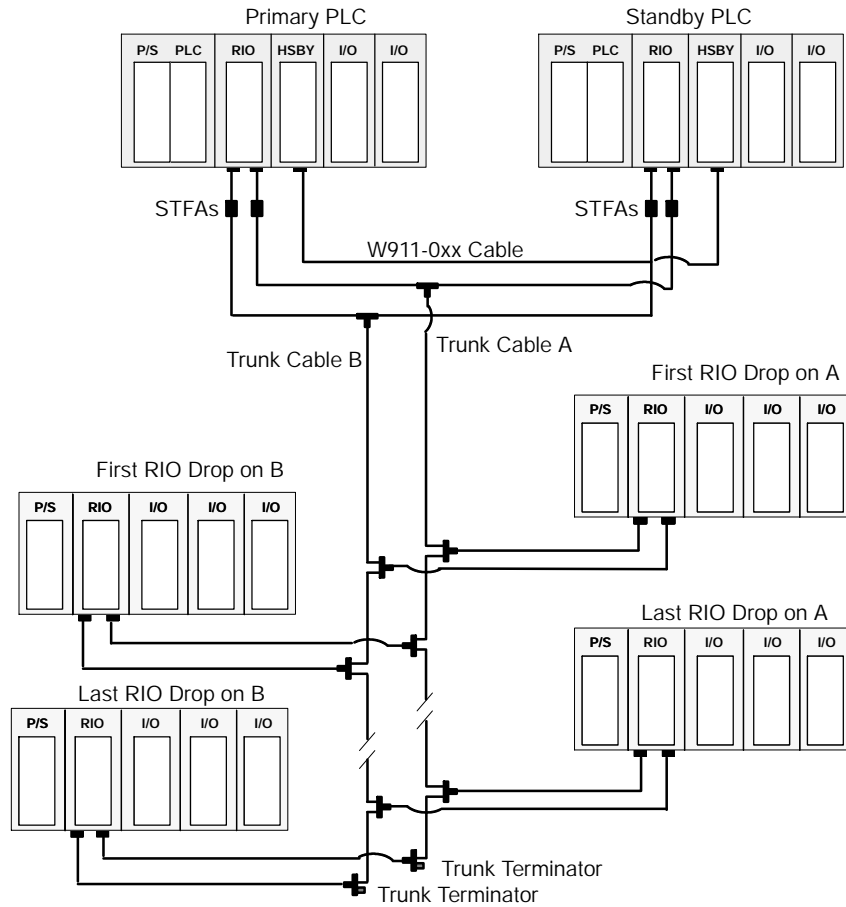



## 2.3 Illegal Coaxial Cable Topologies

Given below are several examples of coaxial cable design topologies that are either not recommended or not permitted on an RIO network.

### 2.3.1 Using a Splitter as a Branching Device

Using a single splitter as a branching device on the trunk is permitted, but it is not recommended. If a splitter is used, the trunk extensions running from it must be balanced to prevent signal reflections. A time domain reflectometer (TDR) must be used to balance the trunk extensions.

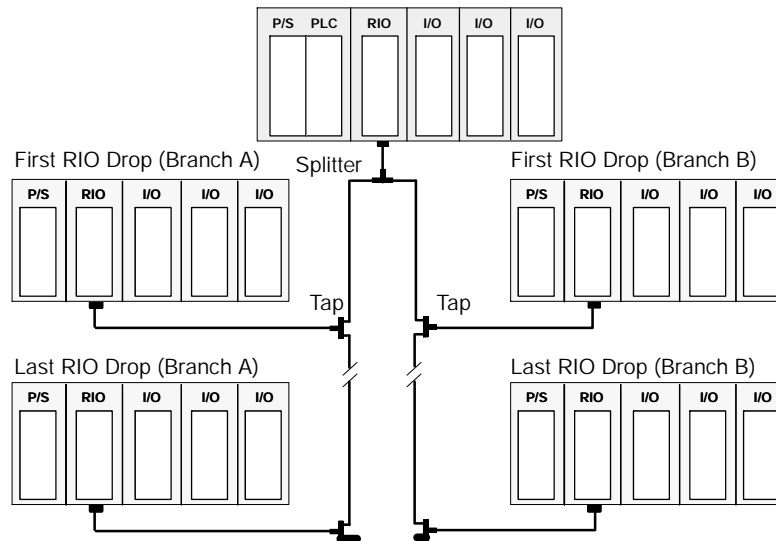

**Caution** The use of more than one splitter as a branching device on an RIO network is *never* permitted.

### 2.3.2 Illegal Trunk Cable Termination

Remote drops cannot be connected directly to the trunk cable—i.e., a remote drop cannot be used to terminate the trunk:

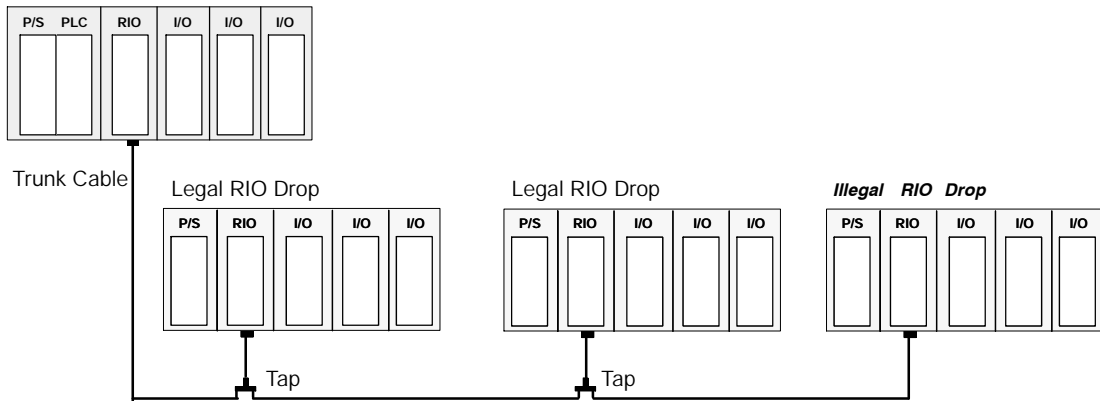

All remote drops on an RIO network must be connected to a trunk cable via a tap and a drop cable, and the last tap on a trunk cable must be terminated with a 75  $\Omega$  Modicon 52-0422-000 Trunk Terminator.

### 2.3.3 Open Taps

If a tap is inserted on the trunk for future use and does not currently have a drop cable connected to it, it must be terminated with a Modicon 52-0402-000 Tap Port Terminator.

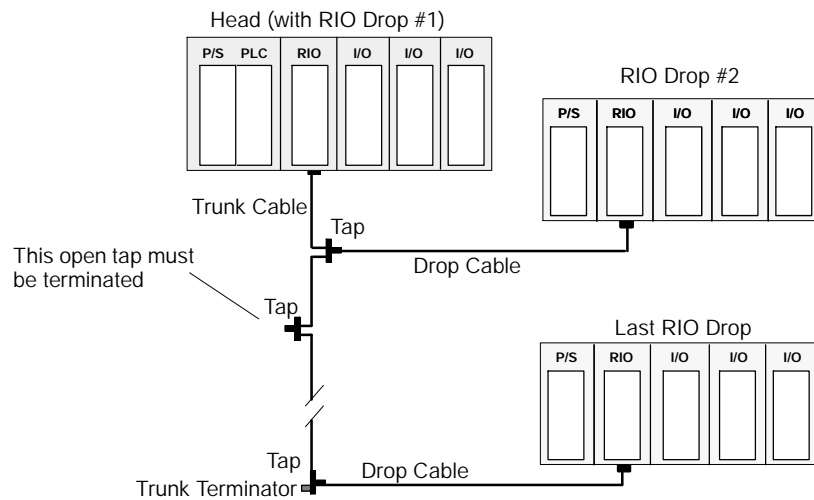

### 2.3.4 Illegal Trunk Cable Connections

*Star* topologies (which use multiple splitters and multiple terminators on trunk and drop cables) and *ring* topologies (which form a loop of trunk cable with no terminator) are not permitted in cable systems consisting of coaxial cable only:

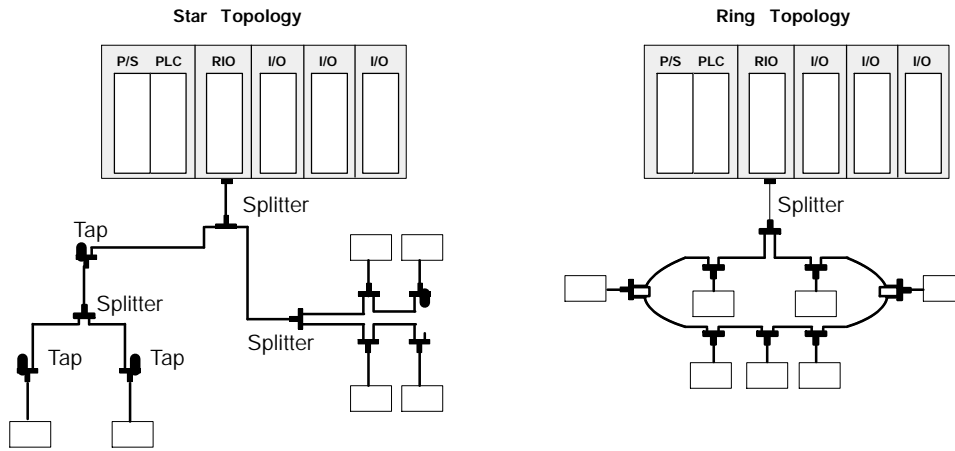

These kinds of topologies do become permissible when fiber optic cable is used (see pages 23 ... 25).

### 2.3.5 Illegal Drop Cable Connections

Branching is not permitted on a coaxial drop cable:

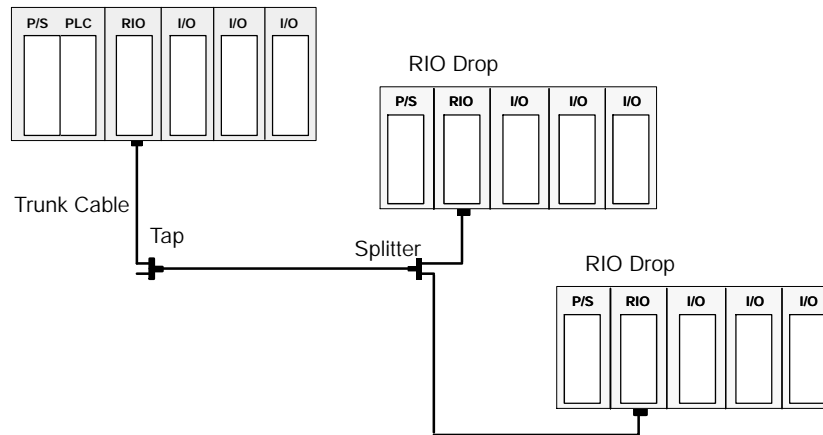

Branching is permissible when fiber optic cable is used (see page 22).

## 2.4 Using Fiber Optics in an RIO System

---

490NPR954 Fiber Optic Repeaters can be introduced in an RIO cable topology to allow you to transition from coaxial to fiber cable then back again to coax at one or more of the remote drops on any RIO network. Fiber optics allow you to:

- Extend the total length of the RIO installation
- Significantly improve the noise immunity characteristics of the installation
- Create topologies that would be illegal if built with coaxial cable alone



**Note** The coaxial cable running into a fiber optic repeater is a drop cable—i.e., coming off a tap from the trunk cable. The coaxial cable coming out of a fiber optic repeater is a trunk cable—i.e., taps must be connected to it to support the drops and it must be properly terminated at the end of the run.

The RIO port on a fiber optic repeater has the same electrical specifications and restrictions as a head RIO processor with a pre-amp—e.g., the RIO signal output from the fiber link back onto the coaxial cable has a dynamic range of 35 dB.

### 2.4.1 Point-to-point Topology with Fiber Optics

The following illustration shows two segments of RIO coaxial cable connected point-to-point by two 490NRP954 Fiber Optic Repeaters. The fiber link may be run over much longer distances than a coaxial drop cable, and through harsh environments with noise immunity that cannot be achieved with copper wire.

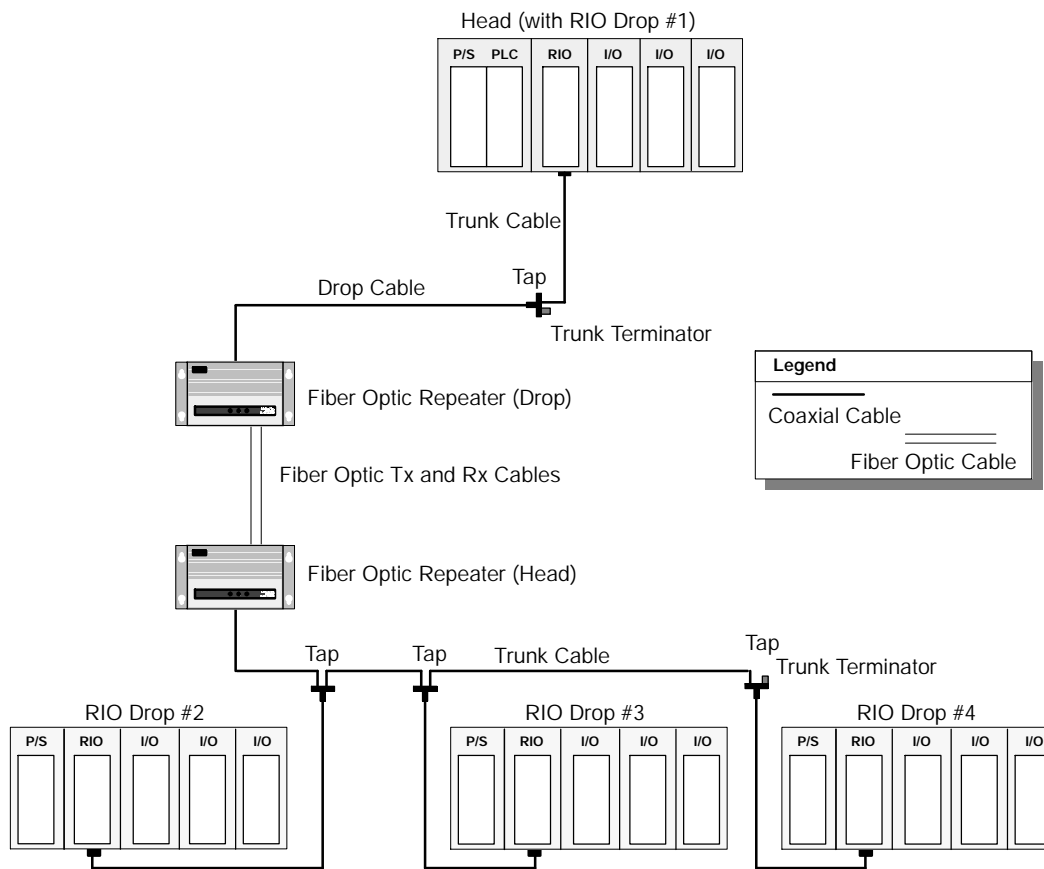

The distance between the two repeaters is limited by the maximum allowable attenuation of the fiber optic cable used in the installation. Fiber attenuation is calculated separately from coaxial cable attenuation (see Section 2.14 on page 43 for details).

**Note** The repeater that has a hard-wired (coaxial) connection to the head processor at the top of the RIO network is called the *drop* repeater. The repeater that has an optical connection to the head processor at the top of the RIO network is called a *head* repeater.

## 2.4.2 Bus Topology with Fiber Optics

Additional fiber optic repeaters can be chained together to extend the length of the fiber link and increase the distance between drops on the RIO network.

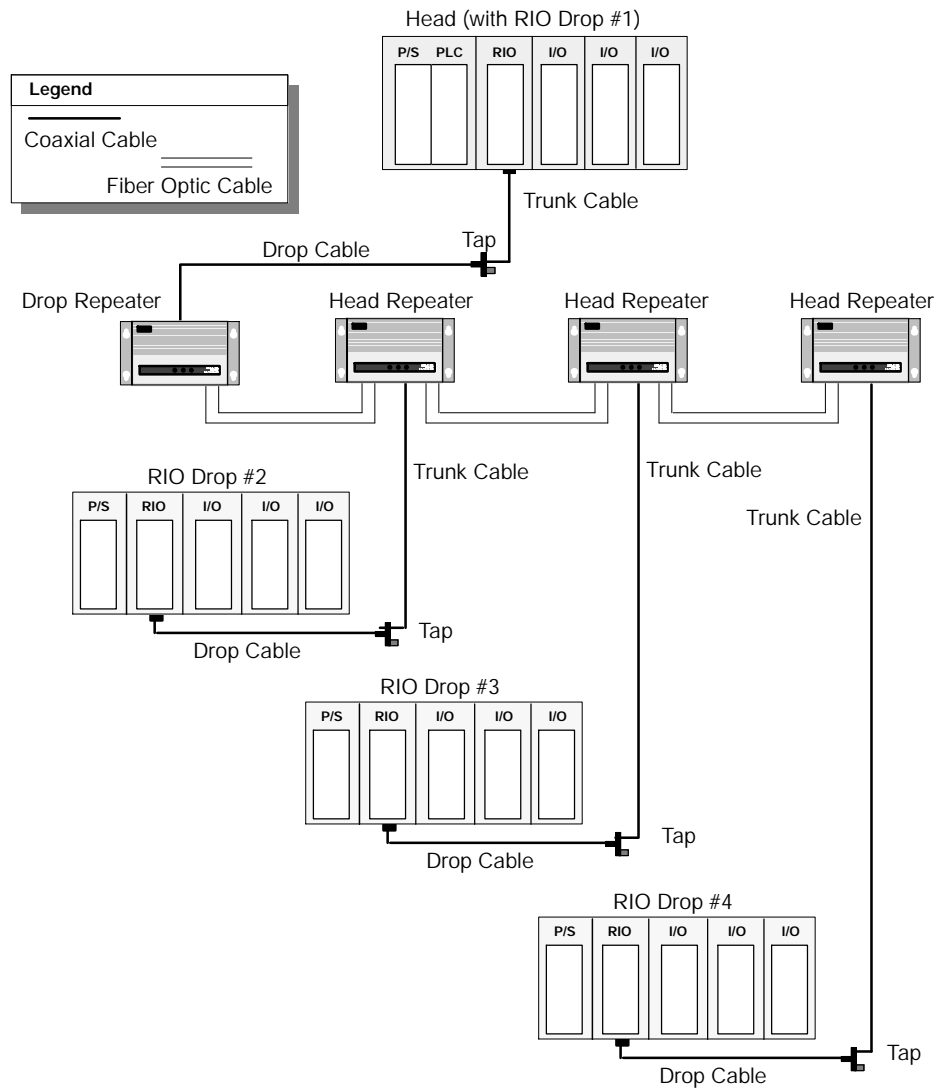

The number of chained repeaters that can be linked in a bus topology like this is determined by the total pulse width distortion (jitter) that occurs on the system (see Section 2.15 on page 46 for the calculation).

### 2.4.3 Star and Tree Topologies with Fiber Optics

Star and tree topologies, which cannot be established with coaxial cable alone (see page 19), can be built legally using fiber optic repeaters. The following tree topology is legal on an RIO fiber optic link:

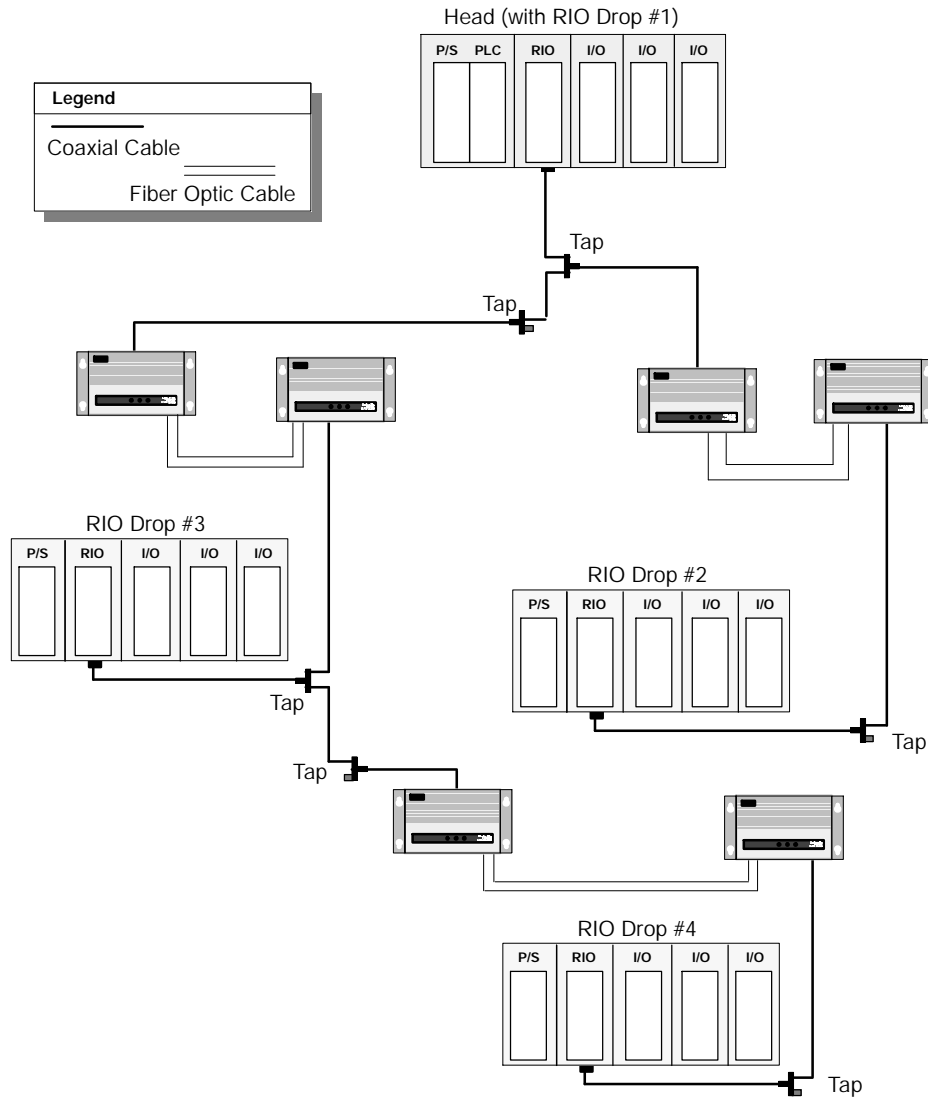

Commercially available passive optical star coupler devices can also be introduced to the optical link to provide added flexibility to the RIO network. A typical four-port star coupler could be used as follows on an RIO fiber optic link:

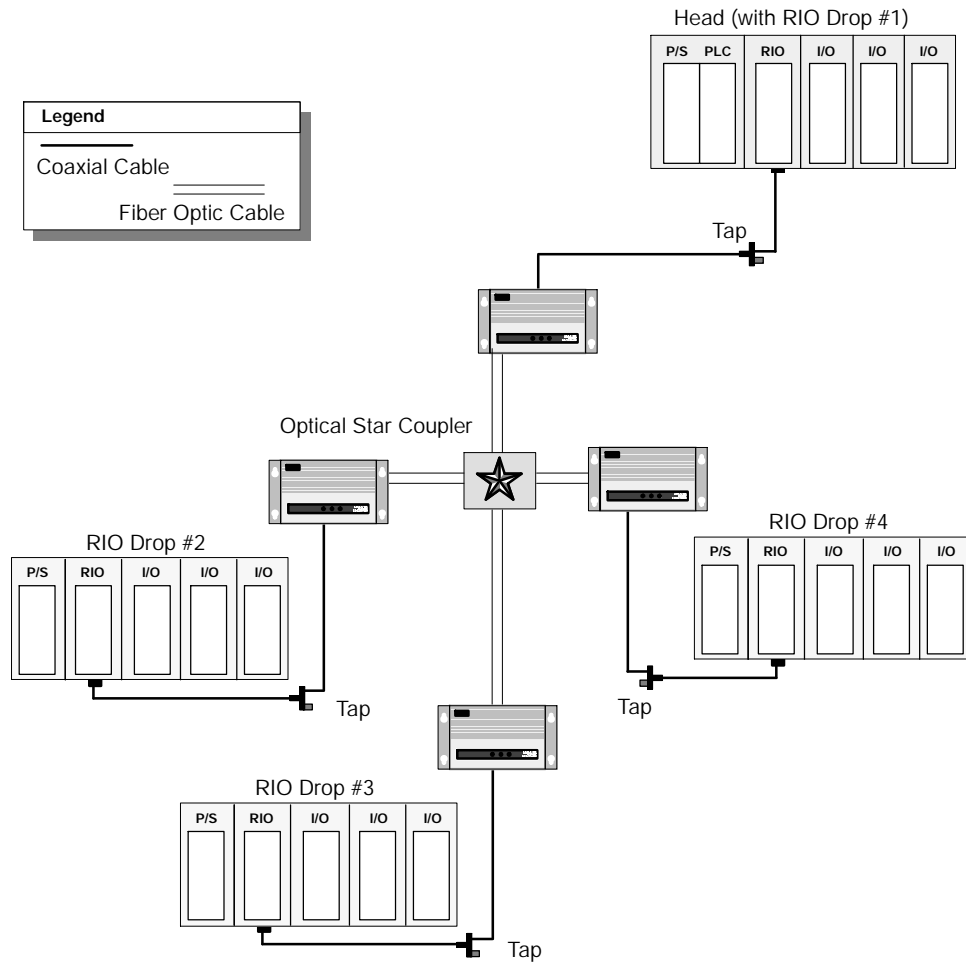

If a passive optical star coupler is used:

- The number of repeaters and the length of each segment of fiber cable must be calculated separately
- 100/140  $\mu\text{m}$  fiber cable is recommended because of its higher available optical power



## 2.4.4 Self-healing Ring Fiber Optic Topology

The 490NRP954 Fiber Optic Repeaters have special features built into the signal timing that allow multiple repeaters to be interconnected in a closed-loop ring. The advantage of a ring topology is that if a break occurs anywhere in the ring, it will reconfigure the network so that communications can continue.

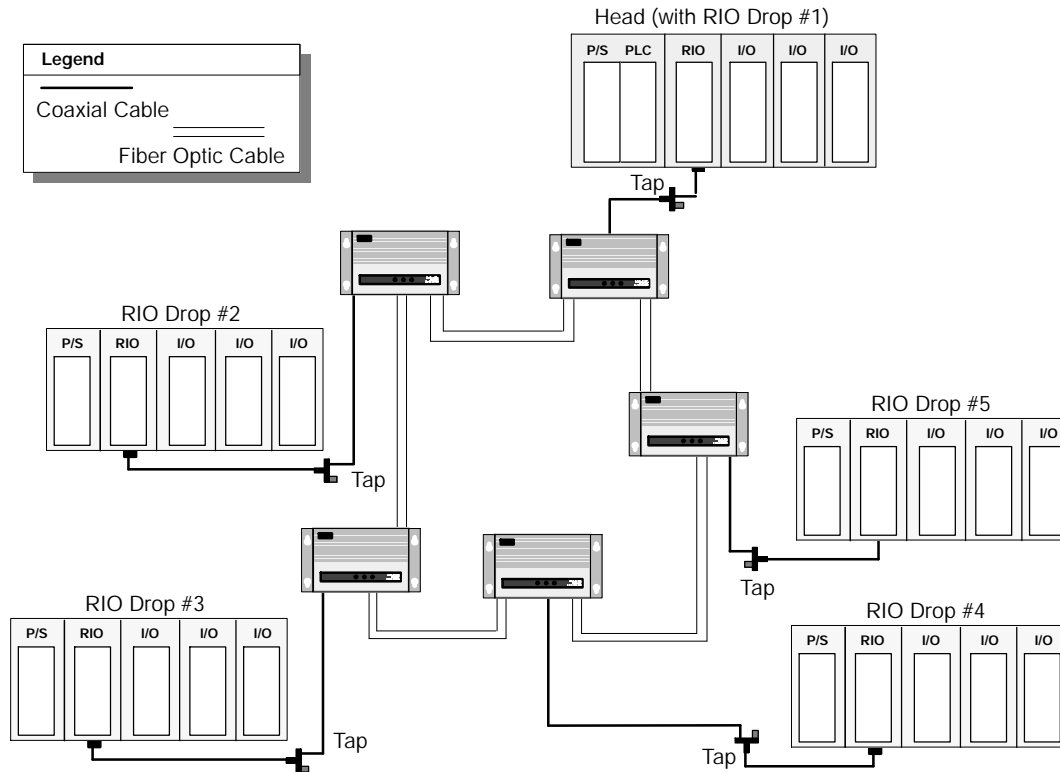

The RIO signal is sent down both legs of the ring by the drop repeater—simultaneously to the head repeaters. A feature is built into the repeaters so that when a signal is received on one of the Rx lines the other Rx channel is blanked—this prevents the same signal from being transmitted twice in the ring.

The maximum length of fiber cable that can be used in a self-healing ring is 10 km (32,000 ft).

 **Note** No sense bit is sent in a self-healing ring topology, and fault detection can be accomplished only via visual inspection of the indicator lights on each repeater or physical status of the cable.

## 2.5 RIO System Design

---

When designing an RIO cable system, consider:

- Whether you will route one or two cables to the remote drops
- The node limitations—e.g., single-port or dual port, ASCII device support
- The expansion capabilities of the PLCs—i.e., the maximum number of drops supported
- The number of nodes —head processors and drop adapters
- The locations and the environmental conditions in which these nodes must operate

### 2.5.1 Key Elements in a Cable System Plan

- The cable system must be dedicated to RIO—no other signals or power can be applied or transmitted on this network
- The attenuation between the head processor (or the last fiber optic repeater, if an optical link is used) and any drop adapter must not exceed 35 dB at 1.544 MHz (32 dB the host-based 984 PLCs)
- The maximum length of the trunk cable is determined by the specified attenuation of the cable type and the number of other cable hardware components along the network
- The minimum length permitted for a drop cable is 8.5 ft (2.5 m)—a shorter drop cable can create tap reflections that cause errors in the drop adapter
- The maximum coaxial drop cable length is 164 ft (50 m)—it can be expanded with a fiber optic link
- Minimum bend radiuses specified for the trunk and drop cables must not be exceeded
- The cable must be routed away from AC and DC power cables
- The physical cable installation must be well supported, and cable pull strength must be considered

- Expansion and contraction loops should be put into the cable system to allow for temperature changes
- Band marked trunk cable is useful for determining tap placement
- The cable system should be single-point grounded within 20 ft of the RIO processor—the central ground point may be a tap, a splitter, or a ground block



**Note** Document your decisions for the installer and for future reference by maintenance personnel. Use the guidelines on page to document the system.

### 2.5.2 Planning for System Expansion

The potential for system expansion should be considered in the initial design. It is less costly to provide for expansion in the original RIO network plan than to redesign the network later. If your PLC is able to support more RIO drops than your current plan requires, consider installing additional taps along the network trunk cable.

If, for instance, you intend to use a 140 CPU 213 04 Quantum CPU—which could support up to 31 remote drops—and your current plan calls for only 10 remote drops, you can install as many as 21 extra taps for future expansion. Remember that the unused expansion taps need to be terminated (see Section 3.11.1 on page 77).

A minimum spacing of 8.5 ft (2.5 m) must be maintained between taps. Each unused port in a tap needs to be terminated with a Modicon 52-0402-000 75  $\Omega$  Tap Port Terminator.

## 2.6 Choosing Coaxial Cables for an RIO Network

Your choice of cables for an RIO network is very important. Semirigid cable offers the highest performance trunk cable, but it requires professional installation. Flexible cable is simpler to install but has more signal loss—and thus causes more distance constraints. RG-11 flexible cable is generally recommended for use as the trunk, but RG-6 flexible cable may be used as a trunk cable on some small networks. RG-6 is used most often as the drop cable.

### 2.6.1 Coaxial Cable Construction

In all cases, we recommend the use of high grade, well shielded industrial cable for trunk and drop cables on an RIO network. Physically, the cable is a single center conductor of copper, copper-plated aluminum, or copper plated steel surrounded by an outer conductive material, the *shield*. The center conductor and shield are separated by an insulating material called the *dielectric*. The most common dielectric material is polyethylene foam. The shield is usually made of aluminum foil and/or copper braid or some other type of metal braid. The foil provides 100% center conductor shielding. The shield may have an insulator surrounding it called the *jacket*. The most common jacket material is polyvinylchloride (PVC).

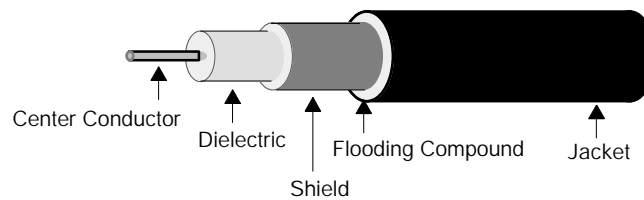

Better quality cables use multiple foil and braid shields:

Shield Type	Shield Effectiveness
Braid	Approximately 50 dB
Foil	Approximately 80 dB
Foil + Braid	Approximately 95 dB
Foil + Braid + Foil ( <i>tri-shield</i> )	Approximately 105 dB
Foil + Braid + Foil + Braid ( <i>quad shield</i> )	>110 dB
Semirigid	>120 dB

### 2.6.2 Flexible Cable

Two types of flexible cable can be used in Modicon RIO cable systems—RG-6 and RG-11.

RG-6 is a  $\frac{5}{16}$  in flexible cable with moderate noise immunity and moderate signal loss (typically 0.48 dB/100 ft at 1.544 MHz, although the loss varies among manufacturers and cable types). Most applications use RG-6 for drop cables; RG-6 can be used as the trunk cable on small networks.

Modicon 97-5750-000 RG-6 quad shield cable can be ordered on 1000 ft rolls; Modicon also provides pre-assembled RG-6 drop cables in 50 ft (AS-MBII-003) and 140 ft (AS-MBII-004) lengths. Other RG-6 cables for special environmental requirements have been approved for use in RIO cable systems—a complete list of all approved RG-6 cables and their performance specifications is provided on pages 54 ... 56.

RG-11 is a  $\frac{3}{8}$  in flexible cable with good noise immunity and low signal loss (typically 0.24 dB/100 ft at 1.544 MHz). RG-11 cable is suitable for use as trunk cable in most industrial applications and may be used as drop cable in very high noise environments.

Modicon 97-5951-000 RG-11 quad shield cable can be ordered on 1000 ft rolls. Other RG-11 cables for special environmental requirements have been approved for use in RIO cable systems—a complete list of all approved RG-11 cables and their performance specifications is provided on pages 57 ... 60.

### 2.6.3 Semirigid Cable

Semirigid cable construction is similar to that of flexible cable except that it uses a solid aluminum shield for 100% shield coverage. Semirigid cable has high noise immunity and very low signal loss (typically 0.10 dB/100 ft at 1.544 MHz with  $\frac{1}{2}$  in cable), making it ideally suited for the main trunk cable when maximum distance and/or high noise immunity is needed. It is not generally used for drop cable because of its inflexibility.

Semirigid cable is available in sizes that usually range from  $\frac{1}{2}$  ... 1 in (sizes at or close to  $\frac{1}{2}$  in are most common). Other sizes are also available. A complete list of all approved semirigid cables and their performance specifications is provided on pages 61 ... 64.

## 2.7 Coaxial Cable Characteristics

---

### 2.7.1 Cable Bend Radius

All cables have a minimum allowable bend radius—i.e., a certain degree beyond which it cannot be bent—and a minimum support requirement. If the cable is bent more than the allowable bend radius or if the installation is not adequately supported, you can easily damage the center conductor, the dielectric, and cable shield.

This damage can cause signal waveform reflections back into the cable system and distortions due to cable impedance alterations away from 75  $\Omega$ . The end result will be a series of transmission errors or a nonfunctioning cable system. The situation creates a high voltage standing wave ratio (VSWR) on the system—high VSWR causes the transmitted signal to reflect back to the source.

When designing the cable system, consult the manufacturer's specifications on the cable bend radius. Design the routing of the cable so that when rounding corners with cable, the cable is not bent more than the specification and put this specification on the design drawings.

### 2.7.2 Cable Support

Most cable manufacturers recommend that RG-11 and RG-6 cable be supported at least every 50 ft (15 m). Consult the cable manufacturer for more detail about minimum support requirements for other types of cable.

### 2.7.3 Cable Pull Strength

Every cable has a maximum allowable pull strength. Any cable that must be pulled through wiring ducts or conduit should have its pull strength labeled on the design drawings. If cable is pulled beyond the maximum allowable limits, the cable will stretch or break causing an impedance mismatch. The stretch or break may not be apparent in a visual inspection—e.g., the dielectric inside the cable could become damaged or the center conductor could break. Cable pull strength ratings can be obtained from the cable manufacturer—they are also listed in the cable specifications given on pages 54 ... 64.

### 2.7.4 Environmental Considerations

Cable components will degrade if subjected to extremes of temperature and humidity. Consult the manufacturer specifications on the cable components

used in the RIO network to assure they meet the requirements of the application.

Provide excess cable in each cable segment of your cable run to allow for temperature changes. Cable system components will expand and contract as a result of temperature variations. Several inches of excess cable should be provided to ensure the cable will not be damaged by temperature changes. Consult the cable manufacturer for the expansion and contraction specifications.

Cable must also be protected from environments that contain corrosive chemicals, rodents, excessive cable strain and other hazards. Modicon 99-0181-000 Sealing Tape may be used to protect connections from environmental problems.

## 2.8 Electrical Characteristics of Coaxial Media Components

---

The following electrical characteristics must be considered when choosing the media components for your network cable system. These characteristics determine the maximum length of the cable system and the number of nodes permitted on the network.

### 2.8.1 Impedance

Impedance is the AC resistance of a cable or network component to a signal. All RIO media components have a characteristic impedance of  $75 \Omega$ , with a minimum tolerance of  $\pm 3 \Omega$ . Media components that can obtain a consistent impedance as close to  $75 \Omega$  as possible yield better performance.

### 2.8.2 Attenuation

Attenuation is the amount of signal loss through media components. Cable and other media components express attenuation in deciBels (dB). Lower attenuation of media components allows for higher signal strength and longer cable distances throughout the cable system.

RIO networks are limited to a maximum attenuation of 35 dB from the RIO head processor (or from the last fiber optic repeater in an optical link) to any drop adapter (32 dB for controllers without pre-amps). Although all media components have attenuation values, the primary attenuation consideration is in your coaxial cable selection. A cable's ability to carry a signal is mostly determined by the physical size of the cable. A larger cable can carry a signal farther than a smaller cable. Here are some rule-of-thumb cable loss figures:

Cable Type	Attenuation at 1.544 MHz
1 in semirigid	0.05 dB/100 ft
$\frac{1}{2}$ in semirigid	0.09 dB/100 ft
RG-11	0.24 dB/100 ft
RG-6	0.48 dB/100 ft

Exact attenuation specifications for all approved cable are given on pages 39 ... 49.



### 2.8.3 Return Loss

Return loss is the measurement of reflected signal strength due to impedance mismatch. This measurement is expressed as a number of dB down from the original signal. Components with a higher return loss are better.

If every component of a network were exactly 75  $\Omega$ , the return loss would be very high. In the real world this is impossible. Even the slightest impedance mismatch will cause a portion of the signal to be reflected. This reflection can subtract from or add to the originally transmitted signal, causing distortion of the original waveform.



**Note** Return loss problems may be avoided by making all trunk and drop cable purchases from the same manufacturer and the same manufacturing batch. Ask the manufacturer to pretest the cable for impedance mismatch.

## 2.9 EMI/RFI Considerations in a Coaxial Cable Routing Plan

---

Electromagnetic interference (EMI) and radio frequency interference (RFI) sources can be avoided by using effectively shielded cable and by routing the cable away from troublesome locations.

### 2.9.1 Guidelines for Interference Avoidance

- Avoid installation of RIO cables in trays or conduits that contain AC or DC power cable or power sources
- Separate RIO cable from power cable or power sources; trunk cable runs should avoid panels, trays, and other enclosures that contain power wires.



**Note** We recommend that a spacing of 12 ... 14 in/kV of power be maintained between the RIO cable installation and power cables.

- Make sure that any RIO cable power cable crossings are at right angles only
- Use cables with a 100% shield, preferably cable with tri- or quad shielding
- Where rodents may be a problem, protect the cable installation by using conduit or a similar material
- Precautions should be taken when the media components are installed in hostile environments where high temperatures or corrosives exist—consult cable manufacturers and/or CATV suppliers for other special products for harsh environments
- Do not route trunk cable into equipment cabinets or panels—trunk cable and taps should be mounted away from cabinets or panels in a separate enclosure (One satisfactory method is to install the trunk cable in the ceiling of the facility and mount the taps within an enclosure up in the ceiling. The drop cable can then be installed down to the node.)
- Do not exceed the cable's minimum bend radius and pull strength
- Make sure the cable is adequately supported—some manufacturers suggest that RG-6 and RG-11 cable be supported at least every 50 ft; contact the manufacturer to make sure you do not exceed the strain limit of the cable
- Install cable in steel conduit in high noise environments

## 2.10 Tap Connections and Locations

---

Each tap has three ports—a trunk-in port, a drop cable port, and a trunk-out port; the RIO cables connect to the tap ports via F connectors. The taps come mounted to a plastic block that is used to isolate them from ground. They must be surface mounted to a wall or an enclosure. Make sure that no tap in the RIO system is grounded or touched by a grounded metallic surface unless it is being used intentionally as the single grounding point for the entire system.

### 2.10.1 Using Band Marked Trunk Cable

Improper placement of taps can cause signal reflections and distortion of the signal waveform. Proper placement will keep these reflections to a minimum and avoid problems with waveform distortion. The preferred method of tap placement is on cable band markers.



**Note** If taps are placed too close to each other (or too close to a splitter in a Hot Standby system), a cumulative reflection will result. To avoid this problem, install taps at least 8 ft 2 in (2.5 m) away from one another.

Trunk cable should be purchased from the manufacturer with band markers applied at regular intervals. Intervals will vary based on the propagation of the cable. Modicon RG-11 trunk cable is band marked at 8.86 ft (2.7 m) intervals; RG-6 cable is not band marked. If you are not using Modicon RG-11 for trunk cable, you can instruct your cable manufacturer to apply marker at the required intervals. The cost to perform band marking is very small.

The occasional placement of two directly connected taps is possible, but not recommended. If taps are installed together, no more than two taps should be connected, and the next multitap connection should be at least 100 ft (30 m) away.

### 2.10.2 Tap Port Connections

An RG-11 cable can connect directly to a tap port F connector via an Modicon 52-0401-000 F Connector installed on the end of the cable (see Section 3.8.3 on page 73).

Quad shield RG-6 cable can be connected to a tap port F connector via a Modicon MA-0329 001 F Connector (see Section 3.8.1 on page 72). Non-quad shield RG-6 cable can be connected to a tap port F connector via a Modicon 52-0400-000 F Connector.

Semirigid cable is more difficult to connect to the two (trunk-in and trunk-out) F connector ports on the tap. Because there is only a 1 in space between the two ports, you may not be able to fit semirigid connectors directly on both ports. To avoid this problem, we recommend that you use high quality 90 degree right angle F adapters such as the Modicon 52-0480-000 Right Angle F Adapter (see Section 3.9 on page 74).

### 2.10.3 Optional Tap Enclosure Considerations

Although not required for overall network integrity, you may consider mounting the taps in separate enclosures away from equipment panels. Potential performance improvements include:

- Avoiding panels, trays, and other enclosures that contain power wiring
- Protecting the network from disruptions caused by accidental trunk cable damage (drop cable damage usually does not disrupt the entire network)
- Performing wiring for future system expansion within panels to avoid rerouting the cable later
- Coiling any excess cable within the tap enclosure



**Note** If excess cable is to be coiled within, the recommended enclosure dimensions are 2 ft (610 mm) long by 2 ft (610 mm) wide by 4 in (102 mm) deep.

Where your overall system design permits it, you may consider locating the enclosures in the ceiling of the facility to further protect against mechanical damage to the trunk and taps.



**Caution** Do not mount a tap within a panel or enclosure that contains control equipment—the trunk and tap become susceptible to potential problems arising from power source noise, and the cable can be damaged due to movement by workers or by poor bend radiuses.

## 2.1 1 Grounding and Surge Suppression

---

Choose a low impedance earth ground for your cable system, preferably factory ground. Use 10 gauge wire or larger to ground the cable system. Use a common single-point ground for the cable system and for all equipment associated with the system. A separate ground—e.g., a computer ground—may actually cause more noise because the RIO nodes will not be connected to it.

### 2.1 1.1 Earth Ground

A low impedance earth ground is necessary on RIO cable systems to assure safety for maintenance personnel and RIO users. The earth ground also provides a path to dissipate noise on the cable system. If the ground is poor or nonexistent, a hazardous shock problem may exist, the cable system will be susceptible to noise, and data transmission errors will occur.



**Note** All nodes connected to the cable system must be grounded. Under no circumstances should ungrounded equipment be connected to the cable system.

### 2.1 1.2 Lightning Protection for RIO Cable Systems

Surge suppressors are recommended when a cable system is installed outdoors or in any environment where lightning protection is required. The surge suppressor contains a gas filled tube and two in-line splice connection points. If lightning strikes the cable system or an excessive voltage is present on the center conductor of the cable, the surge protector will short the center conductor to ground for the duration of the voltage spike (see page 83).

The surge suppressor must be grounded in order to work properly, but this can create a ground loop noise problem. Care must be exercised to assure that ground loops do not cause communications errors. An 8 gauge or larger diameter green or bare grounding wire is recommended for the surge suppressor.

## 2.12 Terminating a Coaxial Cable System

---

Ideally, all connections on the RIO network are terminated with 75  $\Omega$  terminators at all times. Depending on the criticality of your application, you may choose to disconnect a drop cable from a drop adapter for short-term maintenance. The trunk cable and any unused tap ports must remain terminated at all times.

### 2.12.1 Terminating the Trunk Cable

To prevent the build-up of a standing wave that can destroy communications integrity on the network, the trunk cable must be terminated at all times with a Modicon 52-0422-000 Trunk Terminator (see Section 3.11.2 on page 77). The trunk terminator is inserted in the trunk-out port of the last tap on the trunk cable. Do not terminate a trunk cable by connecting it directly to the drop adapter.

### 2.12.2 Terminating Unused Tap Ports

Unused taps may be installed along the trunk for future system expansion. These taps will not have drop cables connected to them, and they must be terminated at all times with Modicon 52-0402-000 Tap Port Terminators (see Section 3.11.1 on page 77).

### 2.12.3 Terminating the Drops

Open connections on a drop cable can subject the network to impedance mismatches and retries. Your application may be able to tolerate these errors for short-term maintenance—e.g., swapping a device in the drop—but if you intend to leave the drop cable disconnected from the drop adapter for a long time or if you are running a critical application elsewhere on the network, you should put a 75  $\Omega$  terminator on the drop cable. You can install a female F connector on the drop cable at the time you disconnect it, then install a Modicon 52-0402-000 Tap Port Terminator. The drop will always remain terminated as long as the cable is connected to the RIO drop adapter, even when the device is turned OFF or removed from the I/O rack (*exception: the adapter devices and Motion modules listed in Section 1.4.4*).

Optionally, you may design a mechanical terminator into all the drop cables—such as a Modicon 52-0411-000 Self-terminating F Adapter; this adds up-front cost to your system design but assures you of a completely balanced system at all times.

## 2.13 Designing a Coaxial Cable System to an Attenuation Limit

---

Attenuation happens naturally as a communication signal passes through taps, splitters, splices, cable, connections, and feed-through terminators. Your goal as designer is to provide successful RIO services while holding the attenuation to a maximum of 35 dB (32 dB in the case of the 984 host-based PLCs) from the head processor to any drop adapter on the network.



**Note** If your cable design exceeds the maximum attenuation limit for your PLC, transmission errors can occur on the network.

### 2.13.1 Cable Attenuation

The most important decision the system designer must make with regard to signal loss is the type of cable used in the system. Many designers use semirigid cable for the trunk cable in high noise environments or when maximum distance is necessary. But the majority of RIO networks use the more flexible RG-6 and RG-11 cables.

RG-6 can be used as a trunk cable, but its best use is as a drop cable. It can be used as the trunk on small networks. RG-6 has more attenuation than RG-11.

### 2.13.2 Tap Attenuation

All drop adapters must be connected via a tap—never directly to a trunk cable. A direct trunk connection causes a severe impedance mismatch. All RIO taps have a tap drop loss of 14 dB and an insertion loss of 0.8 dB:

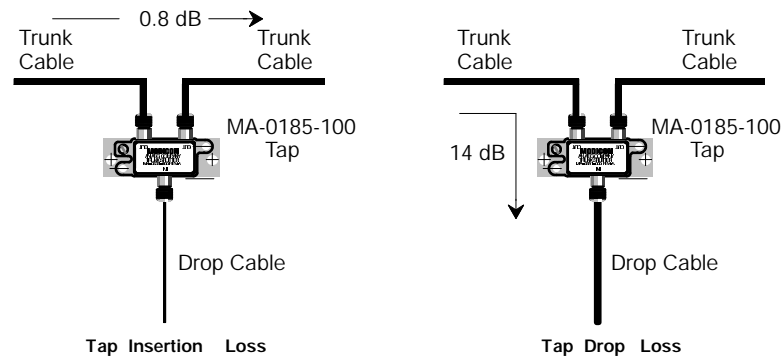

### 2.13.3 Calculating Maximum System Attenuation

To calculate maximum attenuation, add all sources of attenuation between the RIO head processor and a drop adapter; the total loss must not exceed 35 dB (32 dB for controllers without pre-amps). The maximum attenuation for the system is generally measured from the RIO processor node to the last drop adapter on the network. The last adapter usually represents the maximum loss of the entire cable system. There are exceptions however—adapters near the end of the cable system with long drop cables may have greater attenuation.

Maximum system attenuation at 1.544 MHz can be calculated as follows:

$$\text{dB loss} = TCA + DCA + TDA + (NOS \times 6) + (NOT \times 0.8)$$

where

- *TCA* = the trunk cable attenuation from the head to the end of the trunk
- *DCA* = the drop cable attenuation, generally at the last drop
- *TDA* = 14 dB, the tap drop attenuation
- *NOS* = the number of splitters in the system
- *NOT* = the number of taps between the last node and the head



**Note** On a network using dual or redundant trunk cables, calculate attenuation on each separately. Each trunk on a dual or redundant RIO network can handle attenuation up to 35 dB (or 32 dB).

### 2.13.4 Calculating Attenuation on a Coaxial Network—An Example

Here is a sample calculation of total attenuation in a five-drop RIO cable system. The calculation is made between the head processor and the adapter at drop 5. The distance between the head and the last tap is 2179 ft.



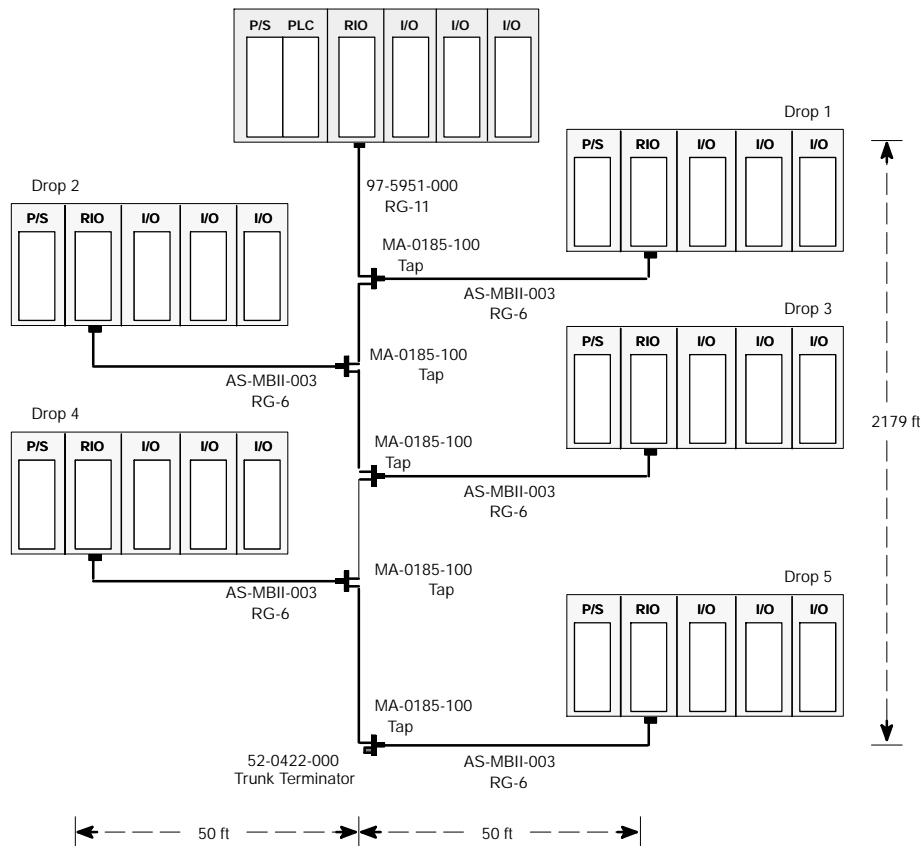

This system uses (Modicon 97-5951-000) RG-11 cable for the trunk; its specified attenuation is 0.24 dB/100 ft at 1.544 MHz. Running to the adapter at drop 5 is a Modicon AS-MBII-003 RG-6 drop cable, a 50 ft cable with an attenuation of 0.3 dB. To calculate end-to-end attenuation on the trunk cable (*TCA*), multiply 0.24 dB (the trunk attenuation per 100 ft) by 21.79:

$$TCA = 0.24 \text{ dB} \times 21.79 = 5.23 \text{ dB}$$

Each drop cable is run from a Modicon MA-0185-100 tap in the trunk cable. Four of these taps lie between our two end points, and we must calculate their tap insertion loss (*TIL*):

$$TIL = NOT \times 0.8 \text{ dB} = 4 \times 0.8 = 3.2 \text{ dB}$$

The drop cable attenuation (*DCA*) at drop 5 has been predetermined as 0.3 dB. The attenuation of the tap (*TDA*) at drop 5 is 14 dB. Since this system does not use a splitter, the *NOS* is 0.

Thus, the total attenuation for this RIO network is

$$5.23 + 0.3 + 14 + 3.2 = 22.73 \text{ dB}$$

**Proper RIO Cable System Design Characteristics**

This example shows a properly designed RIO cable system with

- Total attenuation less than 35 dB
- No drop cables longer than 164 feet (50 m)
- Combined cable distance (drop and trunk cables) less than 8400 ft (2560 m)

## 2.14 Calculating Attenuation on an Optical Path

---

The attenuation that occurs on an RIO fiber optic link is calculated separately from attenuation on the coaxial system. Attenuation on an optical link is calculated based upon an optical power loss budget specified for the type of fiber optic cable you are using. The sum of the losses in all components used in an optical path must not exceed the specified power loss budget for the chosen cable type.

Any of three possible cable core diameters can be used on an optical link:

Core Diameter	Attenuation	Optical Power Loss Budget
50/125 $\mu\text{m}$	3.5 dB/km	7.0 dB
62.5/125 $\mu\text{m}$	3.5 dB/km	11.0 dB
100/140 $\mu\text{m}$	5.0 dB/km	16.5 dB

The specified power loss budget already takes into account a system margin of 3 dB loss at the two ST-type connectors. Only external components such as additional connectors, star couplers, splices, and actual cable attenuation, should be taken into account in calculating the loss.

### 2.14.1 Minimum Distance between Repeaters

The transmit optical power of a fiber cable depends greatly on its size. High optical power may be required in optical links that use star coupler or splitter devices, and in these cases the 100/140  $\mu\text{m}$  cable can be used. The use of 100/140  $\mu\text{m}$  cable requires that you calculate the minimum distance between repeaters. Minimum distance for 100/140  $\mu\text{m}$  cable is calculated as follows:

$$\frac{\text{Maximum Optical Power} - \text{Maximum Received Signal}}{\text{Cable Attenuation}}$$

The optical transmitter in the fiber optic repeater has a maximum optical power of 4 dBm for 100/140  $\mu\text{m}$  cable and a maximum received signal of 10 dBm for any size cable. Thus, the minimum distance between repeaters is:

$$\frac{(4 \text{ dBm}) - (10 \text{ dBm})}{5 \text{ dB/km}} = 1.2 \text{ km}$$



**Note** For long or short distances with minimal distortions, the use of 62.5/125  $\mu\text{m}$  cable is the recommended solution. There is no minimum distance requirement for 50/125 or 62.5/125  $\mu\text{m}$  cable.

### 2.14.2 Example—Attenuation on a Simple Optical Link

Here is an example of a point-to-point optical connection that uses 3 km of 62.5/125  $\mu\text{m}$  fiber optic cable. There is one splice in the cable connection.

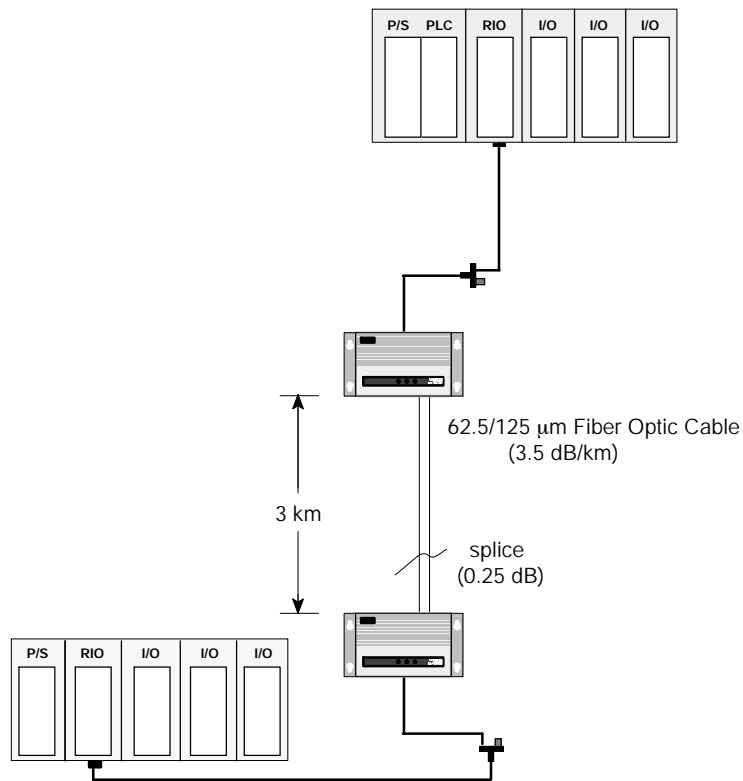

The specified power loss budget for a link using this optical cable is 11 dB. We know that the cable's attenuation over 3 km is  $3.5 \text{ dB/km} \times 3 = 10.5 \text{ dB}$ , and we are given an attenuation of 0.25 dB for the cable splice. Thus, we have a total optical power loss of 10.75 dB on the link, which is under budget and therefore legal.

### 2.14.3 Example—An Optical Link with a Star Coupler

Here is a sample optical link that uses a Kaptron 502402-4 4x4 Star Coupler with 100/140  $\mu\text{m}$  fiber cable. The cable is connected to the star coupler with four pairs of ST-type connectors, and the longest fiber path between any two repeaters (FR1 and FR3) is 1 km.

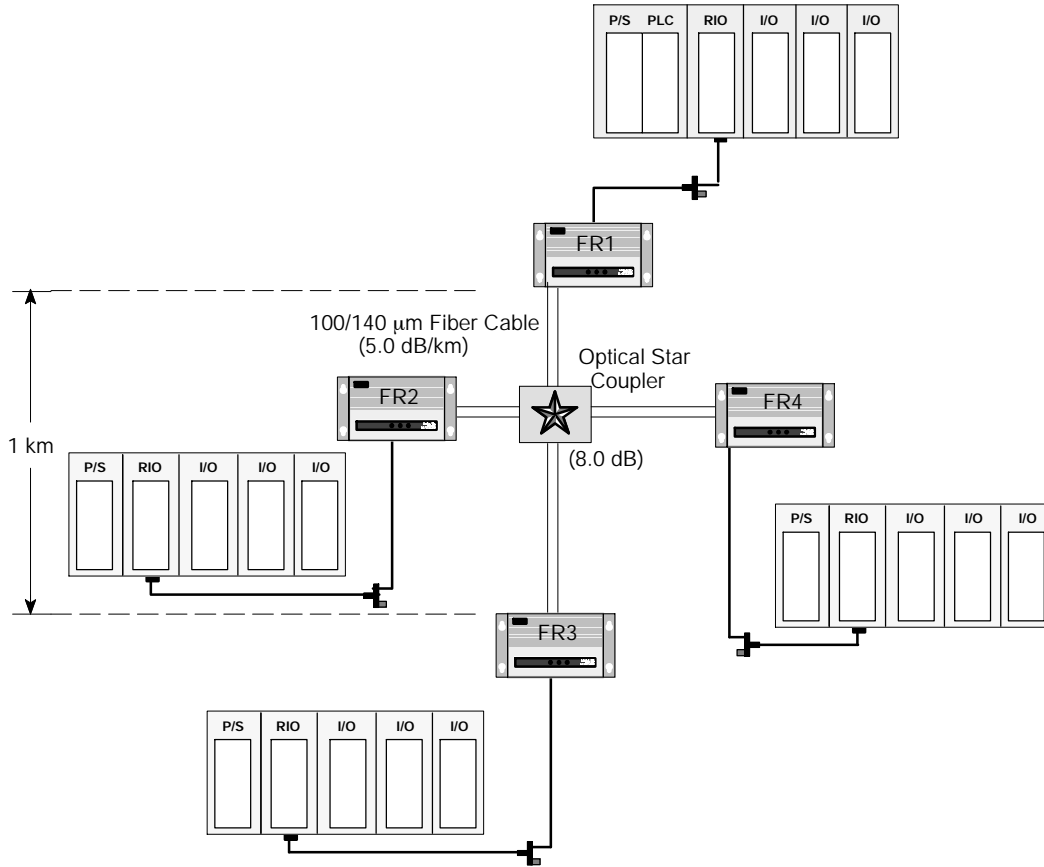

The specified power loss budget for a link using this optical cable is 16.5 dB. The cable attenuation over 1 km is 5 dB, and an attenuation of 8 dB is specified for the star coupler device itself. Two ST connectors for the Tx and Rx lines through the star coupler incur 1 dB loss each. Thus, we have a total optical power loss of:

$$5 + 8 + 1 + 1 = 15 \text{ dB}$$

on the link, which is under budget and therefore legal.

## 2.15 Pulse Width Distortion in a Fiber Optic Bus Topology

---

The number of chained repeaters is limited by the system's total pulse width (jitter) distortions. Shown below is the total amount of jitter contributed by fiber optic cable for the approved fiber cables for 820 nm with  $\pm 50$  nm of spectral width optical signal:

Cable Core Diameter	Pulse Width Distortion (Jitter)
50/125 $\mu\text{m}$	3.0 ns/km
62.5/125 $\mu\text{m}$	5.0 ns/km
100/140 $\mu\text{m}$	7.5 ns/km

The total allowable jitter in the RIO system is limited to 130 ns.

The jitter contributed by the fiber optic repeaters is 10 ns per box. The jitter contributed by the RIO electrical interface is 40 ns (receive-transmit).

The formula to determine the number of chained repeaters ( $n$ ) is:

$$n = \frac{130 \text{ ns} - (x * L) \text{ ns} - 40 \text{ ns}}{10 \text{ ns}} + 1$$

where:

$x$  = jitter specified for the selected cable (from the table above)

$L$  = total length of fiber cable in the optical path (in km)

### 2.15.1 Example—Calculating the Number of Repeaters on a 10 km Optical Path

In this example, we want to establish a fiber optic bus across a 10 km distance, and we want to know how many repeaters can be used on this bus. The cable being used is 62.5/125  $\mu\text{m}$ , which experiences 5 ns/km of jitter. Therefore, the calculation looks like this:

$$n = \frac{130 \text{ ns} - (5 * 10) \text{ ns} - 40 \text{ ns}}{10 \text{ ns}} + 1 = 5$$

The calculation shows us that five repeaters connected on a fiber bus will allow communication across a 10 km bus using 62.5/125  $\mu\text{m}$  cable.

 **Note** You must also take into account point-to-point attenuation between repeaters in the optical path in your plan. For example, if you calculate the number of repeaters needed over a distance of 14 km using 62.5/125  $\mu\text{m}$  cable using the formula given above, the result is four:

$$n = \frac{130 \text{ ns} - (5 \times 14) \text{ ns} - 40 \text{ ns}}{10 \text{ ns}} + 1 = 3$$

However, if you try to use just three repeaters over 14 km, then the best point-to-point distance between two contiguous repeaters is 7 km.

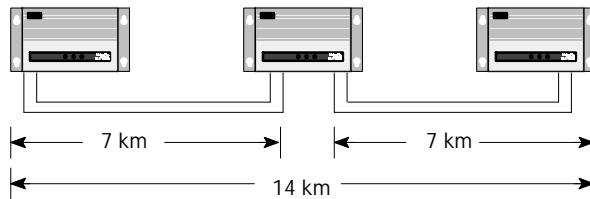

If you calculate attenuation over a 7 km point-to-point optical path (see page 44), your attenuation will exceed the power loss budget for 62.5/125  $\mu\text{m}$  cable. Therefore, a distance of 14 km is too long to be supported.

## 2.16 Planning RIO Drops

---

The maximum length for Modicon's recommended drop cable is 164 ft (50 m). Keeping the drop cable lengths within this limit helps reduce attenuation on the drop and noise problems on the system. The minimum length for a drop cable is 8.53 ft (2.5 m)—shorter drop cable generates unacceptable signal reflections from the tap.

RG-6 is the more commonly used drop cable—it has fair noise immunity and good flexibility. RG-11 cable can also be used—it has better noise immunity and lower loss; RG-11 is recommended in high noise environments.

### 2.16.1 Connecting the Drop Cable to the Drop Adapter

All drop adapters connect to a coaxial drop cable via either an F connector or a BNC connector:

RIO Adapter	RIO Cable Connection	Drop Termination
J890/J892-00x	BNC connector	In the drop adapter
J890/J892-10x*	F connector(s)	
P890/P892		
P451/P453		
140 CRA 931 00/ 932 00		

\* The older J890/J892-00x Adapters use a BNC connector and require a 75  $\Omega$  in line terminator in drop cable.

Each drop adapter must be connected separately to a tap port. The tap isolates the drop from other drops on the network and also from the trunk cable. Multiple adapters cannot be connected on the same port of a tap. Since an adapter is not directly connected to any other node on the network, most installation and noise-related problems at a drop will not reflect across the entire RIO system.

RIO drop adapters cannot be connected directly to the trunk; they must be connected to a drop cable that is connected to a tap. Direct connection of adapters will cause a severe trunk impedance mismatch.



### **2.16.2 Minimizing Low Receive Signal Level Problems**

Some RIO processing devices have a dynamic range of +0 dBmV to +35 dBmV for receiving signals. Any signal below +0 dBmV cannot be received. No indication will be given that the signal is too low, but signal levels that vary above and below this figure will exhibit an increased bit error rate. (This is why the attenuation between any two nodes must not exceed 32 ... 35 dB.)

Problems related to dynamic range can be difficult to find, and can vary from day to day. Therefore, a properly designed system should provide a sufficient margin of error that allows for variances in the signal level—e.g., a receive level of +1 dBmV or above, attenuation of 32 dB between the RIO head and the adapter at the most remote drop.

### **2.16.3 Documenting Your Cable System Design**

The cable system should be fully documented. As you work with the installer to determine a full list of requirements, make a detailed topological drawing of the system layout. The detailed plan should include the cable types, all the cable system hardware in position, and the complete cable routing plan.

As a starting point, you can document the design in less detail using the five specification forms that follow. This initial plan does not give the installer all the routing information, but does give the most important information.

Customer:  
Location:  
Revision/Approved by:

Network:  
Plant:  
Date:

---

**Trunk Cable Materials**

---

Trunk Cable Manufacturer:  
Model #:  
Quantity Needed:  
dB Loss (per 100 ft or m):  
Maximum Pull Strength (lb or kg):  
Minimum Bend Radius (in or mm):

---

Trunk Cable Connector Manufacturer:  
Model #:  
Quantity Needed:

---

Trunk Terminator Manufacturer:  
Model #:  
Quantity Needed:

---

Trunk Splice Manufacturer:  
Model #:  
Quantity Needed:

---

Trunk Grounding Block Manufacturer:  
Model #:  
Quantity Needed:

---

Misc. Connector Manufacturer:  
Model #:  
Quantity Needed:

---

Misc. Connector Manufacturer:  
Model #:  
Quantity Needed:

---

Misc. Connector Manufacturer:  
Model #:  
Quantity Needed:

---

**Drop Cable and Tap Materials**

---

Drop Cable Manufacturer:  
Model #:  
Quantity Needed:  
dB Loss (per 100 ft or m):  
Maximum Pull Strength (lb or kg):  
Minimum Bend Radius (in or mm):

---

Self-terminating F Adapter Manufacturer:  
Model #:  
Quantity Needed:

---

Drop Cable F Connector Manufacturer:  
Model #:  
Quantity Needed:

---

Tap Manufacturer:  
Model #:  
Number of Ports:  
Through Loss (dB):  
Drop Loss (dB):  
Quantity Needed:

---

Tap Manufacturer:  
Model #:  
Number of Ports:  
Insertion Loss (dB):  
Drop Loss (dB):  
Quantity Needed:

---

Tap Port Terminator Manufacturer:  
Model #:  
Quantity Needed:

---

Fiber Optic Cable Manufacturer:  
Model #:  
Quantity Needed:  
dB Loss (per optical link):

---

ST-type Connector Manufacturer:  
Model #:  
Quantity Needed:

---



# Chapter 3

## RIO Network Hardware Components

---

- RG-6 Cable
- RG-11 Cable
- Approved Semirigid Cables
- Selecting Fiber Optic Cable
- Hardware Overview
- Tap Specifications
- Splitter Specifications
- F Connectors for Coaxial Cables
- F Adapters for Semirigid Cable
- BNC Connectors and Adapters
- Network Terminators
- Self-terminating F Adapter Options
- Ground Blocks
- Surge Suppressors
- Cable Waterproofing Materials
- Fiber Optic Repeater
- Recommended Materials for a Fiber Optic Installation

## 3.1 RG-6 Cable

---

### 3.1.1 Modicon RG-6 Cable

Modicon 97-5750-000 RG-6 cable, available in 1000 ft rolls, meets the following design specifications:

Modicon 97-5750-000 RG-6 Cable		
Attenuation (at 1.544 MHz)	0.44 dB/100 ft (1.44 dB/100 m)	
Transfer Impedance	at 5 MHz	1.8 mΩ/ft
	at 10 MHz	0.9 mΩ/ft
Impedance and Tolerance	75 Ω (+2 Ω)	
Shield Effectiveness	> 110 dB	
Velocity of Propagation	82%	
Capacitance	16.2 pF/ft	
Type of Shield	Bonded Foil Quad Shield	
Type of Jacket	PVC	
NEC Rating	CL2	
Minimum Bend Radius	2.0 in (50 mm)	
Maximum Pull Strength	200 lb (91 kg)	
Maximum Trunk Cable Distance	4550 ft (1386 m)	
Maximum Drop Cable Distance	164 ft (50 m)	

### Modicon Pre-assembled Drop Cable

Modicon offers pre-assembled drop cables, built with high quality F connectors, a self-terminating F adapter, and a high quality quad shield RG-6 cable. Each assembly is fully tested and certified before shipment to assure conformance to RIO specifications. Assemblies are available in two standard lengths—50 ft (15 m) assembly (AS-MBII-003) and 140 ft (42 m) assembly (AS-MBII-004).

Modicon Pre-assembled Drop Cable Specifications		
Tested Frequency Range	500 kHz ... 30 MHz	
Impedance	5 Ω (+2 Ω)	
Attenuation at 1.5 MHz	50 ft length	0.3 dB maximum
	140 ft length	0.7 dB maximum
Return Loss	24 dB minimum	
Tests Performed	Attenuation Sweep Test, Return Loss Sweep	

### 3.1.2 Other Approved RG-6 Cables

The following RG-6 cables have been tested and approved for Modicon RIO compatibility.



**Note** We recommend that you use only the cables specified in this manual. Modicon will not warrant RIO systems installed with unapproved cable.

<b>Belden 1223A RG-6 Cable NO LONGER AVAILABLE</b>		
Attenuation (at 1.544 MHz)	0.43 dB/100 ft (1.41 dB/100 m)	
Transfer Impedance	at 5 MHz	1.8 mΩ/ft
	at 10 MHz	0.9 mΩ/ft
Impedance and Tolerance	5 Ω (+3 Ω)	
Shield Effectiveness	105 dB	
Velocity of Propagation	81%	
Capacitance	17.3 pF/ft	
Type of Shield	Tri-shield	
Type of Jacket	PVC	
NEC Rating	CL2	
Minimum Bend Radius	2.7 in (69 mm)	
Maximum Pull Strength	157 lb (71 kg)	
Maximum Trunk Cable Distance	4600 ft (1402 m)	
Maximum Drop Cable Distance	164 ft (50 m)	

<b>Belden 9060 RG-6 Cable NO LONGER AVAILABLE</b>		
Attenuation (at 1.544 MHz)	0.67 dB/100 ft (2.20 dB/100 m)	
Transfer Impedance	at 5 MHz	1.8 mΩ/ft
	at 10 MHz	0.9 mΩ/ft
Impedance and Tolerance	75 Ω (+3 Ω)	
Shield Effectiveness	105 dB	
Velocity of Propagation	78%	
Capacitance	17.3 pF/ft	
Type of Shield	Tri-shield	
Type of Jacket	PVC	
NEC Rating	CATV	
Minimum Bend Radius	2.7 in (69 mm)	
Maximum Pull Strength	157 lb (71 kg)	
Maximum Trunk Cable Distance	2900 ft (883 m)	
Maximum Drop Cable Distance	164 ft (50 m)	

**Comm/Scope 5750 RG-6 Cable**

Attenuation (at 1.544 MHz)	0.44 dB/100 ft (1.44 dB/100 m)	
Transfer Impedance	at 5 MHz	1.8 mΩ/ft
	at 10 MHz	0.9 mΩ/ft
Impedance and Tolerance	75 Ω (+2 Ω)	
Shield Effectiveness	110 dB	
Velocity of Propagation	82%	
Capacitance	16.2 pF/ft	
Type of Shield	Bonded Foil Quad Shield	
Type of Jacket	PVC	
NEC Rating	CL2	
Minimum Bend Radius	2.0 in (50 mm)	
Maximum Pull Strength	200 lb (91 kg)	
Maximum Trunk Cable Distance	4550 ft (1386 m)	
Maximum Drop Cable Distance	164 ft (50 m)	

**3.1.3 Approved RG-6 Plenum Cable**

The following RG-6 cable has been tested and approved for a Modicon RIO installation in special environments:

**Comm/Scope 2228 RG-6 Cable**

Attenuation (at 1.544 MHz)	0.47 dB/100 ft (1.54 dB/100 m)	
Transfer Impedance	at 5 MHz	1.4 mΩ/ft
	at 10 MHz	0.6 mΩ/ft
Impedance and Tolerance	75 Ω (+2 Ω)	
Shield Effectiveness	110 dB	
Velocity of Propagation	82%	
Capacitance	16.2 pF/ft	
Type of Shield	Bonded Foil Quad Shield	
Type of Jacket	Teflon or Kynar	
NEC Rating	CL2P	
Minimum Bend Radius	2.0 in (50 mm)	
Maximum Pull Strength	200 lb (91 kg)	
Maximum Trunk Cable Distance	4200 ft (1280 m)	
Maximum Drop Cable Distance	164 ft (50 m)	



## 3.2 RG-1 1 Cable

---

We recommend that you use only the cables specified in this manual. Modicon will not warrant the operation of RIO systems installed with unapproved cable.

### 3.2.1 Modicon RG-1 1 Cable

Modicon 97-5951-000 RG-11 cable is available in 1000 ft rolls:

Comm/Scope 2228 RG-6 Cable		
Attenuation (at 1.544 MHz)	0.24 dB/100 ft (0.79 dB/100 m)	
Transfer Impedance	at 5 MHz	2.00 mΩ/ft
	at 10 MHz	0.65 mΩ/ft
Impedance and Tolerance	75 Ω (+2 Ω)	
Shield Effectiveness	> 110 dB	
Velocity of Propagation	84%	
Capacitance	16.2 pF/ft	
Type of Shield	Bonded Foil Quad Shield	
Type of Jacket	PVC	
NEC Rating	CL2	
Minimum Bend Radius	2.5 in (63.5 mm)	
Maximum Pull Strength	200 lb (91 kg)	
Maximum Trunk Cable Distance	8400 ft (2560 m)	
Maximum Drop Cable Distance	164 ft (50 m)	

### 3.2.2 Other Approved RG-1 1 Cables

The following RG-11 cables have been tested and approved for Modicon RIO compatibility.

Belden Model 1224A RG-1 1 Cable NO LONGER AVAILABLE		
Attenuation (at 1.544 MHz)	0.33 dB/100 ft (1.08 dB/100 m)	
Transfer Impedance	at 5 MHz	0.2 mΩ/ft
	at 10 MHz	0.1 mΩ/ft
Shield Effectiveness	105 dB	
Velocity of Propagation	81%	
Capacitance	16.2 pF/ft	
Type of Shield	Tri-shield	
Type of Jacket	PVC	
NEC Rating	CL2	

Minimum Bend Radius	4.5 in (114 mm)
Maximum Pull Strength	270 lb (123 kg)
Maximum Trunk Cable Distance	6100 ft (1859 m)
Maximum Drop Cable Distance	164 ft (50 m)

**Belden Model 9064 RG-1 1 Cable**

Attenuation (at 1.544 MHz)	0.19 dB/100 ft (0.62 dB/100 m)	
Transfer Impedance	at 5 MHz	1.8 mΩ/ft
	at 10 MHz	0.9 mΩ/ft
Impedance and Tolerance	75 Ω (+2 Ω)	
Shield Effectiveness	105 dB	
Velocity of Propagation	78%	
Capacitance	17.3 pF/ft	
Type of Shield	Tri-shield	
Type of Jacket	PVC	
NEC Rating	CL2	
Minimum Bend Radius	4.5 in (114 mm)	
Maximum Pull Strength	271 lb (123 kg)	
Maximum Trunk Cable Distance	6900 ft (2103 m)	
Maximum Drop Cable Distance	164 ft (50 m)	

**Comm/Scope 5951 RG-1 1 Cable**

Attenuation (at 1.544 MHz)	0.24 dB/100 ft (0.79 dB/100 m)	
Transfer Impedance	at 5 MHz	2.00 mΩ/ft
	at 10 MHz	0.65 mΩ/ft
Impedance and Tolerance	75 Ω (+2 Ω)	
Shield Effectiveness	> 110 dB	
Velocity of Propagation	84%	
Capacitance	16.2 pF/ft	
Type of Shield	Bonded Foil Quad Shield	
Type of Jacket	PVC	
NEC Rating	CL2	
Minimum Bend Radius	2.5 in (63.5 mm)	
Maximum Pull Strength	200 lb (91 kg)	
Maximum Trunk Cable Distance	8400 ft (2560 m)	
Maximum Drop Cable Distance	164 ft (50 m)	

**Comm/Scope 5950 and 5952 RG-1 1 Cable**

Attenuation (at 1.544 MHz)	0.22 dB/100 ft (0.72 dB/100 m)	
Transfer Impedance	at 5 MHz	2.00 mΩ/ft
	at 10 MHz	0.65 mΩ/ft
Impedance and Tolerance	75 Ω (+2 Ω)	
Shield Effectiveness	> 110 dB	
Velocity of Propagation	82%	
Capacitance	16.2 pF/ft	
Type of Shield	Bonded Foil Quad Shield	
Type of Jacket	PVC (5950) or PE (5952)	
NEC Rating	CL2	
Minimum Bend Radius	2.5 in (63.5 mm)	
Maximum Pull Strength	200 lb (91 kg)	
Maximum Trunk Cable Distance	6900 ft (2103 m)	
Maximum Drop Cable Distance	164 ft (50 m)	

 **Note** The Comm/Scope 5952 cable design is similar to Comm/Scope 5950 except that it uses a polyethylene jacket rather than PVC. The PE jacket provides protection against ultraviolet rays and water, and may be used in outdoor applications.

**Comm/Scope 5951 and 5953 RG-1 1 Cable**

Attenuation (at 1.544 MHz)	0.22 dB/100 ft (0.72 dB/100 m)	
Transfer Impedance	at 5 MHz	2.00 mΩ/ft
	at 10 MHz	0.65 mΩ/ft
Impedance and Tolerance	75 Ω (+2 Ω)	
Shield Effectiveness	> 110 dB	
Velocity of Propagation	82%	
Capacitance	16.2 pF/ft	
Type of Shield	Bonded Foil Quad Shield	
Type of Jacket	PVC (5951) or PE (5953)	
NEC Rating	CL2	
Minimum Bend Radius	2.5 in (63.5 mm)	
Maximum Pull Strength	200 lb (91 kg)	
Maximum Trunk Cable Distance	6900 ft (2103 m)	
Maximum Drop Cable Distance	164 ft (50 m)	

 **Note** The Comm/Scope 5953 cable design is similar to Comm/Scope 5951 except that it uses a polyethylene jacket rather than PVC. The PE jacket provides protection against ultraviolet rays and water, and may be used in outdoor applications.

### 3.2.3 Approved RG-1 1 Plenum Cables

The following RG-1 1 cable has been tested and approved for Modicon RIO installations in special environments:

Comm/Scope 2288 RG-1 1 Plenum Cable		
Attenuation (at 1.544 MHz)	0.23 dB/100 ft (0.75 dB/100 m)	
Transfer Impedance	at 5 MHz	2.00 mΩ/ft
	at 10 MHz	0.65 mΩ/ft
Impedance and Tolerance	75 W (+2 Ω)	
Shield Effectiveness	> 110 dB	
Velocity of Propagation	82%	
Capacitance	16.2 pF/ft	
Type of Shield	Bonded Foil Quad Shield	
Type of Jacket	Teflon or Kynar	
NEC Rating	CL2P	
Minimum Bend Radius	2.5 in (63.5 mm)	
Maximum Pull Strength	200 lb (91 kg)	
Maximum Trunk Cable Distance	8700 ft (2651 m)	
Maximum Drop Cable Distance	164 ft (50 m)	

### 3.3 Approved Semirigid Cables

We recommend that you use only the cables specified in this manual. Modicon will not warrant the operation of RIO systems installed with unapproved cable.

The following semirigid cables have been tested and approved for Modicon compatibility:

Comm/Scope QR-860-JCA 0.860 in Semirigid Cable		
Attenuation (at 1.544 MHz)	0.045 dB/100 ft (0.148 dB/100 m)	
Transfer Impedance	at 5 MHz	0.1 mΩ/ft
	at 10 MHz	0.1 mΩ/ft
Impedance and Tolerance	75 Ω (+2 Ω)	
Shield Effectiveness	> 120 dB	
Velocity of Propagation	88%	
Capacitance	15.3 pF/ft	
Type of Shield	Aluminum Sheath	
Type of Jacket	PE	
NEC Rating	CATV	
Minimum Bend Radius	7 in (178 mm)	
Maximum Pull Strength	450 lb (204 kg)	
Maximum Trunk Cable Distance	15,000+ ft (4571+ m)	

Comm/Scope QR-540-JCA 0.540 in Semirigid Cable		
Attenuation (at 1.544 MHz)	0.087 dB/100 ft (0.285 dB/100 m)	
Transfer Impedance	at 5 MHz	0.1 mΩ/ft
	at 10 MHz	0.1 mΩ/ft
Impedance and Tolerance	75 Ω (+2 Ω)	
Shield Effectiveness	> 120 dB	
Velocity of Propagation	88%	
Capacitance	15.3 pF/ft	
Type of Shield	Aluminum Sheath	
Type of Jacket	PE	
NEC Rating	CATV	
Minimum Bend Radius	5 in (127 mm)	
Maximum Pull Strength	200 lb (91 kg)	
Maximum Trunk Cable Distance	15,000+ ft (4571+ m)	

Comm/Scope P-3-75-500-JCA 1/2 in Semirigid Cable		
Attenuation (at 1.544 MHz)	0.087 dB/100 ft (0.285 dB/100 m)	
Transfer Impedance	at 5 MHz	0.1 mΩ/ft
	at 10 MHz	0.1 mΩ/ft
Impedance and Tolerance	75 Ω (+2 Ω)	
Shield Effectiveness	> 120 dB	
Velocity of Propagation	87%	
Capacitance	15.3 pF/ft	
Type of Shield	Aluminum Sheath	
Type of Jacket	PE	
NEC Rating	CATV	
Minimum Bend Radius	8 in (203 mm)	
Maximum Pull Strength	200 lb (91 kg)	
Maximum Trunk Cable Distance	14,500 ft (4419 m)	

Times Fiber T6500* 1/2 in Semirigid Cable		
Attenuation (at 1.544 MHz)	0.089 dB/100 ft (0.292 dB/100 m)	
Transfer Impedance	at 5 MHz	0.1 mΩ/ft
	at 10 MHz	0.1 mΩ/ft
Impedance and Tolerance	75 Ω (+2 Ω)	
Shield Effectiveness	> 120 dB	
Velocity of Propagation	87%	
Capacitance	15.6 pF/ft	
Type of Shield	Aluminum Sheath	
Type of Jacket	PE	
NEC Rating	CATV	
Minimum Bend Radius	5 in (127 mm)	
Maximum Pull Strength	200 lb (91 kg)	
Maximum Trunk Cable Distance	13,900 ft (4236 m)	



**Note** For burial cable, append a B to the part number. For jacketed cable, append a J to the part number.

Times Fiber T6625* .625 in Semirigid Cable		
Attenuation (at 1.544 MHz)	0.073 dB/100 ft (0.240 dB/100 m)	
Transfer Impedance	at 5 MHz	0.1 mΩ/ft
	at 10 MHz	0.1 mΩ/ft
Impedance and Tolerance	75 Ω (+2 Ω)	
Shield Effectiveness	> 120 dB	
Velocity of Propagation	87%	
Capacitance	15.6 pF/ft	
Type of Shield	Aluminum Sheath	
Type of Jacket	PE	
NEC Rating	CATV	
Minimum Bend Radius	7.0 in (178 mm)	
Maximum Pull Strength	300 lb (136 kg)	
Maximum Trunk Cable Distance	15,000 ft (4571 m)	

 **Note** For burial cable, append a B to the part number. For jacketed cable, append a J to the part number.

Times Fiber T6500* 1/2 in Semirigid Cable		
Attenuation (at 1.544 MHz)	0.062 dB/100 ft (0.203 dB/100 m)	
Transfer Impedance	at 5 MHz	0.1 mΩ/ft
	at 10 MHz	0.1 mΩ/ft
Impedance and Tolerance	75 Ω (+2 Ω)	
Shield Effectiveness	> 120 dB	
Velocity of Propagation	87%	
Capacitance	15.6 pF/ft	
Type of Shield	Aluminum Sheath	
Type of Jacket	PE	
NEC Rating	CATV	
Minimum Bend Radius	7.0 in (178 mm)	
Maximum Pull Strength	400 lb (181 kg)	
Maximum Trunk Cable Distance	15,000 ft (4571 m)	

 **Note** For burial cable, append a B to the part number. For jacketed cable, append a J to the part number.

**Times Fiber T6875\* .875 in Semirigid Cable**

Attenuation (at 1.544 MHz)	0.051 dB/100 ft (0.167 dB/100 m)	
Transfer Impedance	at 5 MHz	0.1 mΩ/ft
	at 10 MHz	0.1 mΩ/ft
Impedance and Tolerance	75 Ω (+2 Ω)	
Shield Effectiveness	> 120 dB	
Velocity of Propagation	87%	
Capacitance	15.6 pF/ft	
Type of Shield	Aluminum Sheath	
Type of Jacket	PE	
NEC Rating	CATV	
Minimum Bend Radius	7.0 in (178 mm)	
Maximum Pull Strength	500 lb (226 kg)	
Maximum Trunk Cable Distance	15,000 ft (4571 m)	



**Note** For burial cable, append a B to the part number. For jacketed cable, append a J to the part number.

**Times Fiber T61000 1 in Semirigid Cable**

Attenuation (at 1.544 MHz)	0.046 dB/100 ft (0.151 dB/100 m)	
Transfer Impedance	at 5 MHz	0.1 mΩ/ft
	at 10 MHz	0.1 mΩ/ft
Impedance and Tolerance	75 Ω (+2 Ω)	
Shield Effectiveness	> 120 dB	
Velocity of Propagation	87%	
Capacitance	15.6 pF/ft	
Type of Shield	Aluminum Sheath	
Type of Jacket	PE	
NEC Rating	CATV	
Minimum Bend Radius	7.0 in (178 mm)	
Maximum Pull Strength	590 lb (267 kg)	
Maximum Trunk Cable Distance	15,000 ft (4571 m)	



**Note** For burial cable, append a B to the part number. For jacketed cable, append a J to the part number.



## 3.4 Selecting Fiber Optic Cable

---

If you are using 490NRP954 Fiber Optic Repeaters in your RIO network, there are several parameters you need to consider, among them cable attenuation and cable bandwidth. Parameters are specified by the cable manufacturer and are based on:

- The wavelength of the optical signal—820 nm in the RIO optical link
- The cable index—use graded-index cable only
- The fiber size—50/125  $\mu\text{m}$ , 62.5/125  $\mu\text{m}$ , or 100/140  $\mu\text{m}$

For most optical cable links, the use of 62.5/125  $\mu\text{m}$  cable is recommended because of its relatively low loss and signal distortion. In applications where high optical power is required—e.g., to support additional optical devices such as splitters or star couplers—the 100/140  $\mu\text{m}$  cable should be used (see Section 2.14 on page 43 for more details on design considerations).

Many cable vendors offer multiple choices for a variety of code ratings:

- From the variety of cables—e.g., AMP or Belden offerings—select the one that meets the demands of your application. Wherever possible, Modicon recommends that a multiconductor cable be considered, since it is inexpensive; it provides a backup in case a cable gets cut in the process of pulling it; and you will always find uses for the extra path(s), be it for voice, video, other communications, and/or other control applications.
- Most 62.5/125  $\mu\text{m}$  cables are rated at 3.5 dB loss per km. With a multiconductor cable, all the pairs usually come with an attenuation specification as measured, which may be significantly less than 3.5 dB/km.

## 3.5 Hardware Overview

---

This chapter provides detailed information about the requirements and availability of hardware components for the RIO cable system (see the list on page 67). Many of the components are available directly from Modicon; qualified alternative sources are also given.

### 3.5.1 Required Cable System Hardware Components

All RIO cable systems require the following hardware components:

- Taps to isolate the individual drop adapters from the rest of the network
- F connectors for making drop cable connections at the taps
- F or BNC connectors for making drop cable connections at the adapter
- Terminators to assure a properly balanced network and to keep unwanted signals out of the cable system

A splitter is required in a Hot Standby system to connect the primary and standby PLCs to the trunk cable, and may be used under certain conditions in other RIO cable topologies (see Chapter 2).

### 3.5.2 Optional Cable System Hardware Components

Depending on the types of cable used in the system and on overall demands that will be placed on the network by the application, some of the following hardware options may be used in your RIO cable system:

- Adapters for converting from F to BNC connectors for making high performance semirigid trunk cable connections compatible with standard system hardware
- Self-terminating F adapters or in-line BNC terminators for automatic termination in drop cables should they be disconnected from the drop adapter

### 3.5.3 The Optional RIO Fiber Optics Repeater

The 490NRP954 RIO Fiber Optics Repeater provides an alternative fiber-medium communication link between two or more RIO nodes or network segments. Each repeater contains one electrical RIO interface (an F-connector) and two fiber optic transceivers. The RIO interface has the same specifications and restrictions as a head RIO processor with a pre-amp—e.g., 35 dB dynamic range—and must be treated accordingly.

The repeater is passive—i.e., there is no regeneration of the received signal in the repeater and no additional delay to the signal produced by the repeater.

### 3.5.4 RIO System Hardware Components

Description	Part Number	
Tap	MA-0185-100	
Splitter	MA-0186-100	
F Connectors	quad shield RG-6 (10/cassette)	MA-0329-001
	non-quad shield RG-6	MA-0329-002 52-0400-000
	RG-11 (6/cassette)	52-0401-000
BNC connectors	non-quad shield RG-6	52-0487-000
	quad shield RG-6	043509446
Self-terminating F Adapter	non-quad shield RG-6	52-0399-000
	quad shield RG-6	52-0411-000
In-line BNC terminator	60-0513-000	
Tap port terminator	52-0402-000	
Right angle F connector	52-0480-000	
Fiber optic repeater	490NRP954	
BNC Jack to male F connector	52-0724-000	
Ground block	60-0545-000	
Drop cable warning label	MD-9100-440	
Environmental seal tape	99-0181-000	

## 3.6 Tap Specifications

Modicon MA-0185-100 Taps connect the drop cables to the main trunk cable and isolate the RIO drop adapter from the rest of the network. This tap is *nondirectional*—it allows signals to be propagated in both directions along the trunk cable. An MA-0185-100 tap has one drop port and two trunk ports.

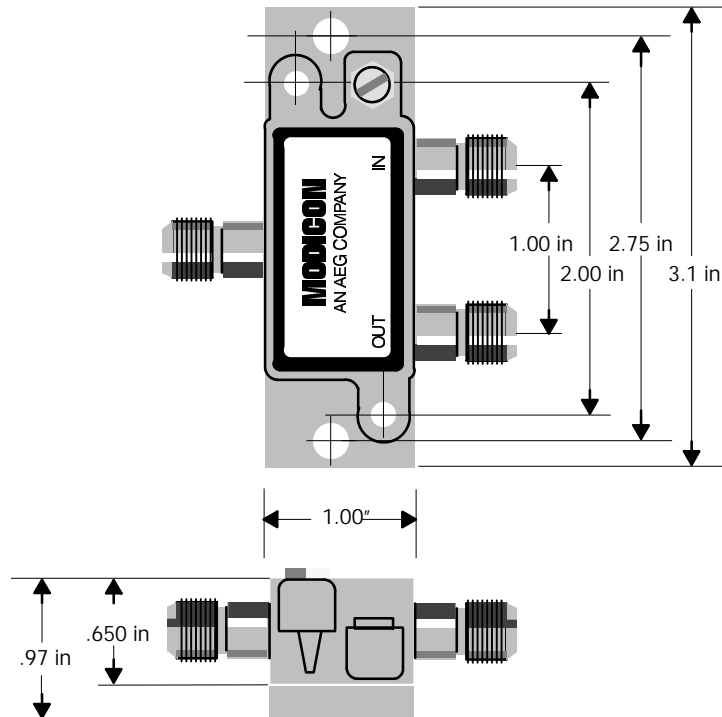

**Note** Although the trunk ports are labeled IN and OUT, these labels can be ignored—i.e., the tap is not directional.

An MA-0185-100 tap is supplied with a plastic isolator on its back. The tap isolates the drop adapter from the trunk cable by 14 dB.

Unused ports on the taps must be terminated—open ports along the network must be terminated with a Modicon 52-0402-000 Tap Port Terminator, and the last (trunk-out) port of the last tap on the network must be terminated with a Modicon 52-0422-000 Trunk Terminator (see page 77).

**MA-0185-100 Tap Specifications**

Impedance	75 $\Omega$
Frequency Range	100 kHz ... 30 MHz
Tap Loss	14 dB (+0.5 dB)
Trunk Insertion Loss	0.8 dB maximum
Trunk Return Loss	26 dB minimum
Tap Return Loss	-18 dB minimum
Temperature Range	40 ... +60 degrees C
Humidity	95% at 85 degrees C
Sealing	RFI/EMI sealed
Interconnections	F Connectors torque up to 90 in/lb
Tap Ports Center Contact	Grips 24 gauge solid conductor after repeated insertions of 16 gauge solid conductor
Tap Ports Connector Threads	$\frac{3}{8}$ -3 2 F Connectors; class 2B-0

Since the trunk ports are 1 in apart, most semirigid connectors do not fit directly onto the tap. If you are using semirigid cable and its connectors do not fit on the trunk ports of the tap, use a Modicon 52-0480-000 right-angle F adapter to make the tap connection.

 **Note** Taps not supplied by Modicon are not supported by Modicon.

 **Note** Older models of the Modicon MA-0185-000 Tap can be used on an RIO network if they are at Revision C.

 **Note** Do not ground a tap unless you are using it specifically as the single-point ground for the entire RIO cable system.

## 3.7 Splitter Specifications

The Modicon MA-0186-100 Splitter must be used as a signal combiner in a 984 Hot Standby cable system; each programmable controller (with an S911 or R911 Hot Standby module in it) has the ability to transmit onto the network using the splitter. A single splitter may also be used as a branching device in certain trunk cable topologies, as defined in Chapter 2.

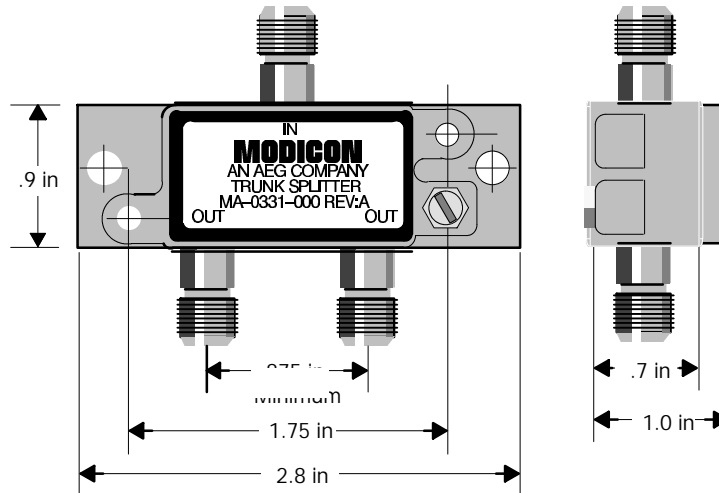

MA-0186-100 splitters have a minimum return loss of 18 dB on each port. Any unused port must be terminated. The splitter is installed between two PLCs in the main trunk cable and has three connectors (ports) on it. Each port is attenuated 6 dB from the other ports. All ports are split equally.

MA-0186-100 Splitter Specifications (for Hot Standby Systems)

Impedance	75 $\Omega$
Frequency Range	100 kHz ... 5 MHz
Trunk Insertion Loss	6.0 dB (+0.5 dB)
Trunk Return Loss	18 dB minimum
Temperature Range	40 ... +60 degrees C
Humidity	95% at 60 degrees C
Sealing	RFI/EMI sealed
Interconnections	F Connectors torque up to 90 in/lb
Tap Ports Center Contact	Grips 24 gauge solid conductor after repeated insertions of 16 gauge solid conductor
Tap Ports Connector Threads	$\frac{3}{8}$ -3 2 F Connectors; class 2B-0

The input port must connect to the RIO processor, and the two output ports must connect to the two trunk cable segments. Each output port loses 3.5 dB insertion loss, referenced to the input port. The isolation between the two output ports is a minimum of 28 dB. The high isolation between output ports ensures less interference between each trunk segment.

Since the trunk connectors on the splitter are 1 in apart, most semirigid connectors do not fit. Check with the manufacturer of the semirigid connectors to ensure they will fit. If they do not fit, use a right angle 90 degree F adapter to connect the semirigid connector to the splitter.

 **Note** Splitters not supplied by Modicon will not be supported by Modicon.

 **Note** Older model splitters with Modicon part number MA-0186-000 can be used in an RIO network if the revision is at least Revision B.

## 3.8 F Connectors for Coaxial Cables

---

Flexible cables (RG-6 and RG-11) use F connectors to make the tap port connections; F connectors are also used to make the drop cable connection to certain drop adapters (see Section 2.16 on page 48). F connectors use a 3/8-32 thread. Always use industrial grade F connectors in RIO cable systems—commercial grade F connectors should not be used.

### 3.8.1 F Connectors for Quad Shield RG-6 Cable

The Modicon MA-0329-001 F Connector is recommended for quad shield RG-6 cable; it is packaged in a plastic cassette that contains ten connectors. These connectors can be purchased only by the cassette. This is the only approved F connector for quad shield RG-6 cable.

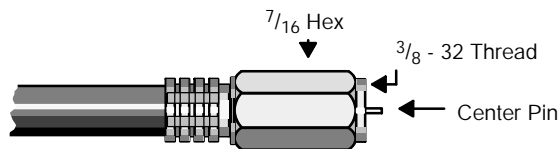

This industrial grade connector has an environmental seal on the front end and uses a machined center pin connection rather than the center conductor of the cable as the connection. Environmental seal tape is available to seal the back of the connector when required. The MA-0329-001 F Connector's center pin is deliberately longer than the EIA 550 FD specified tolerance to assure a proper connection to a female F connector. It uses a crimp fitting to secure it to the cable.

### 3.8.2 F Connectors for Non-quad Shield RG-6 Cable

Either the Modicon 52-0400-000 or MA-0329-002 F Connector can be used with non-quad shield RG-6 cable; it is packaged in a plastic cassette that contains 12 connectors and 12 environmental seal boots. These connectors can be purchased only by the cassette. This is the only approved F connector for non-quad shield RG-6 cable.



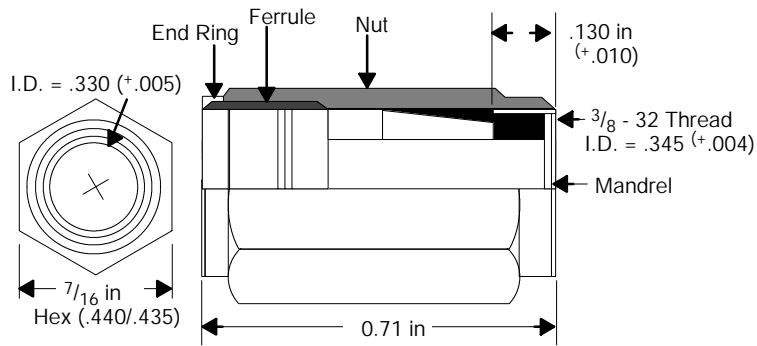

This industrial grade connector has an environmental seal on the back end and uses a boot over the female port to environmentally seal the front of the connector. It does not have a center pin connection. It is installed with a compression fitting—no crimping is required.

### 3.8.3 F Connectors for RG-11 Cable

The Modicon 52-0401-000 F Connector is recommended for all RG-11 cable; it is packaged in a plastic cassette that contains six connectors and six environmental seal boots. These connectors can be purchased only in the cassette. This is the only approved F connector for RG-11 cable.

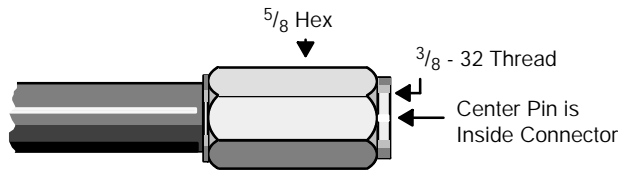

This industrial grade connector fits all types of RG-11 from single-shield to quad shield. It has an environmental seal on the back and uses a boot over the female port to environmentally seal the front. It has a center pin connection that is much more reliable than a center conductor connection and will not damage the female connector. The 52-0401-000 F Connector is installed with a compression fitting—no crimping is required.

### 3.9 F Adapters for Semirigid Cable

---

A Modicon 52-0480-000 Right Angle F Adapter is usually needed to attach semi-rigid trunk cable to the F connector on a tap port; it may also be necessary at other connection points in order to maintain bend radius tolerance on a semirigid cable.

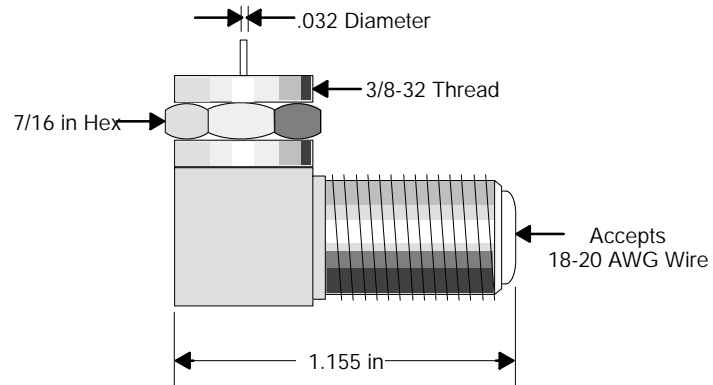

Modicon has also approved the FF90FM right-angle F adapter manufactured by LRC Electronics and the GFMF/90 right-angle F adapter manufactured by Gilbert Engineering.

## 3.10 BNC Connectors and Adapters

---

Some drop cables may require a BNC connector to connect to certain RIO drop adapters (see Section 2.16 on page 48) or to certain RIO processors at the controller head-end. Always use industrial grade BNC connectors or adapters in RIO cable systems—commercial grade hardware should not be used.

### 3.10.1 BNC Connectors for RG-6 Cable

The recommended BNC connectors fit RG-6 cable only. Two sizes of BNC connectors are available for quad shield and non-quad shield RG-6 cables:

- The Modicon 043509446 BNC Connector for quad shield
- The Modicon 52-0487-000 BNC Connector for non-quad shield cable

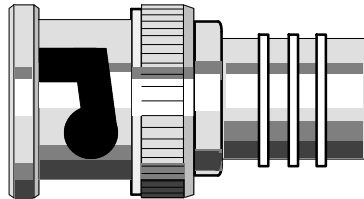

These BNC connectors use crimp-fitted connections.

 **Note** Quad shield cable has a larger outside diameter, so it requires a larger connector. Do not use the wrong size BNC connector for the cable you are using. All Comm/Scope flexible cables are quad shield cables. Belden flexible cables are the only approved non-quad shield cables.

### 3.10.2 F-to-BNC Adapters for RG-11 Cable

There is no approved BNC connector for RG-11 cable. Where a BNC connection is required, use an approved F connector for on the RG-11 cable followed by an adapter connection such as the Modicon 52-0614-000 F-to-BNC Adapter.

 **Note** The S901, S908, or S929 head processors used in the 984A, 984B, and 984X Programmable Controllers require the use of a 52-0614-000 F-to-BNC Adapter.

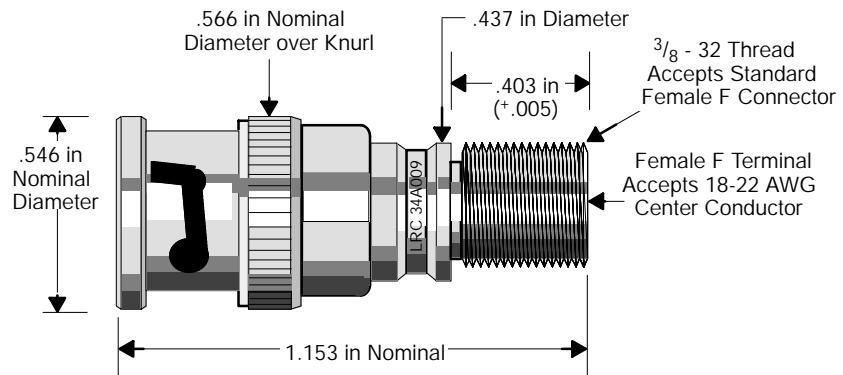

The 52-0614-000 Adapter permits the F connector on an RG-11 trunk cable to be attached to the BNC connector on an RIO processor at the network head-end or the F connector on an RG-11 drop cable to be connected to a J810/J812 or J890/J892 drop adapter at the drop.

### 3.10.3 BNC Jack to Male F Connector

The 52-0724-000 Jack is supplied with the J890/J892-10x RIO drop adapters to terminate cables with BNC connectors.

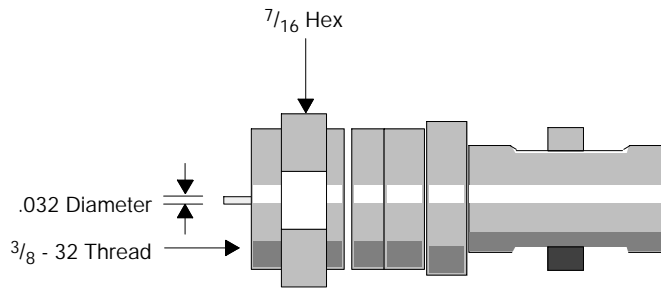

## 3.1.1 Network Terminators

All terminators used on the RIO network must have a power handling capability of at least  $\frac{1}{4}$  W. Terminators designed for power-handling, CATV applications, or broadband cable applications cannot be used on an RIO network—they do not work in the RIO frequency range and will cause signal distortion.

### 3.1.1.1 Tap Port Terminators

All unused drop connectors on taps must be terminated with a standard  $75 \Omega$  tap port terminator. The Modicon 52-0402-000 Tap Port Terminator provides suitable termination for this purpose, with a return loss of 22 dB and a frequency range from 100 kHz ... 30 MHz.

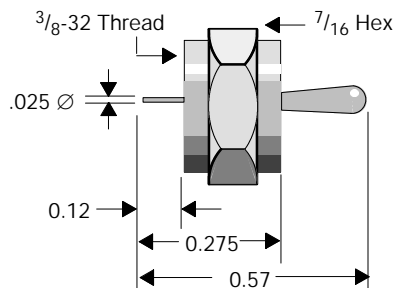

### 3.1.1.2 Trunk Terminators

The trunk cable must be terminated at its tail-end point (in the trunk-out port of the last tap in the trunk cable) with a trunk terminator. The Modicon 52-0422-000 Trunk Terminator is a precision  $75 \Omega$ , 1% tolerance, 14 dB terminating resistor specifically designed for trunk termination. Do not use the 52-0402-000 Tap Port Terminator to terminate the trunk cable. The return loss of the 52-0422-000 Trunk Terminator is 40 dB or better at 10 MHz, and its frequency range is from 100 kHz ... 30 MHz.

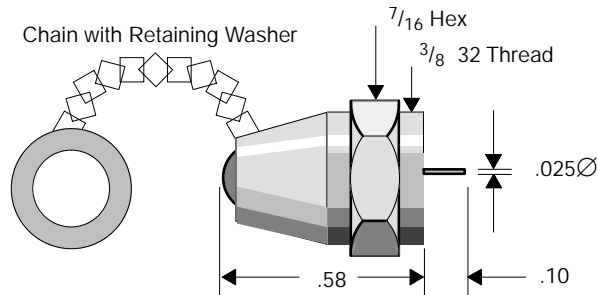

### 3.1 1.3 BNC In-line Terminators

A Modicon 60-0513-000 BNC In-line Terminator is used to terminate the end of a drop cable for nodes that require external  $75 \Omega$  termination—i.e., the older J890/J892-00x Adapters and the Modicon 410 and 3240 Motion products (see the list in Section 1.4.4).

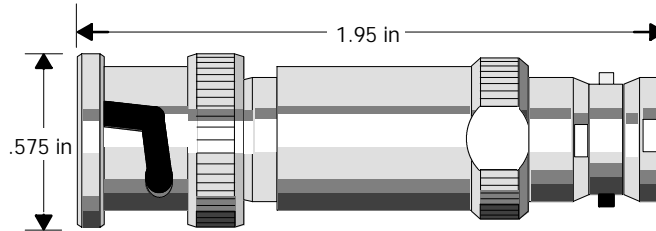

The 60-0513-000 In-line Terminator has two BNC connectors—a female for the incoming drop cable and a male to connect to the drop adapter. It has a return loss of 20 dB (VSWR 1.2:1), a frequency range from DC ... 300 MHz, and an insertion loss of 0.03 dB.

### 3.1 1.4 Self-terminating BNC Adapters for Hot Standby Systems

Modicon 52-0370-000 Self-terminating BNC Adapters are used in 984 Hot Standby systems. They allow one Hot Standby PLC to be disconnected from the network without causing open-circuit communications errors in the other PLC. One side of the terminator has a female F connector, and the other side has a female BNC connector. Only the BNC side should be disconnected while the network is operating. Disconnecting the F connection side will cause an impedance mismatch on the trunk.

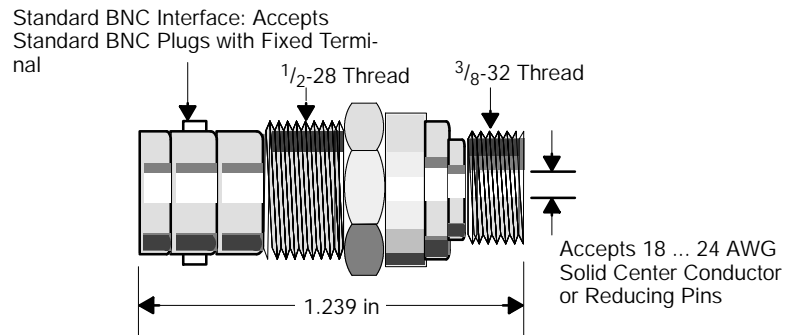

The 52-0370-000 Self-terminating BNC Adapter has a return loss of 40 dB, a frequency range from 100 kHz ... 30 MHz, and an insertion loss of 0.03 dB.

The Modicon 52-0488-000 quad shield BNC Connector and 52-0487-000 non-quad shield BNC Connector are *not* compatible with the self-terminating BNC adapter because there are not enough threads on the terminator. A self-terminating F adapter may be used in place of a self-terminating BNC adapter to avoid connector incompatibility.

### **3.1 1.5 Warning Labels**

The self-terminating BNC adapters require warning labels, which promote proper connection and disconnection practices. Modicon MD-9423-000 Hot Standby Processor Warning Labels wrap around the cable near the self-terminating BNC adapters; connect/disconnect instructions are provided on both sides of the label.

## 3.12 Self-terminating F Adapter Options

As an option for preventing impedance mismatches across the network at all times, you could consider installing self-terminating mechanical devices on all drop cables. The self-terminator may be a self-terminating F or BNC adapter.

### 3.12.1 Self-terminating F Adapters

A 75  $\Omega$  self-terminating F adapter crimps onto the RG-6 drop cable. There are two types of self-terminating F adapters:

- A Modicon 52-0411-000 model for quad shield cable

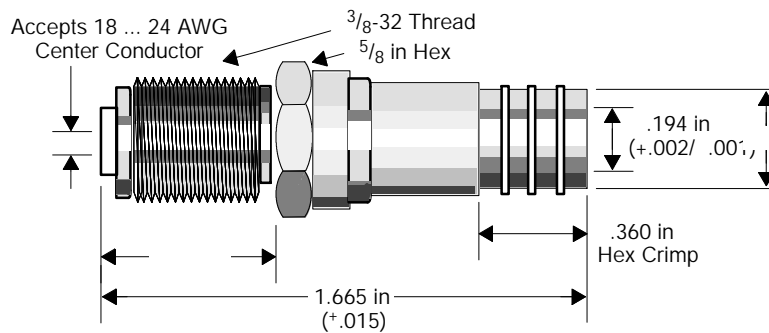

- A Modicon 52-0399-000 model for non-quad shield cable

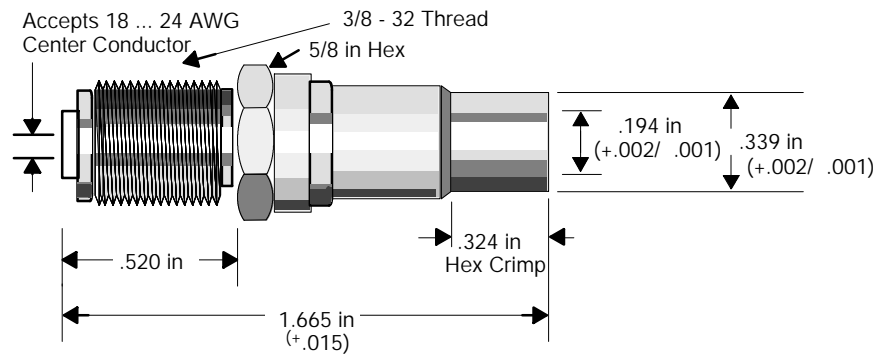

Both of these self-terminating F adapters have a return loss of 22 dB, a frequency range from 100 kHz ... 30 MHz, and an insertion loss of 0.03 dB.



If you are using RG-11 drop cable, a self-terminating F adapter cannot be used. Since only Belden non-quad shield cable is specified for RIO, use the 52-0399-000 self-terminating F adapter only with Belden cable. Plenum cable cannot accept a self-terminating F adapter because of its diameter.

### **3.12.2 Warning Labels**

The self-terminating F adapters require warning labels, which promote proper connection and disconnection practices. Modicon MD-9100-440 Drop Cable Warning Labels wrap around the cable near the self-terminating F adapters; connect/ disconnect instructions are provided on both sides of the label.

### 3.13 Ground Blocks

A cable system must be grounded at all times to assure safety and proper operation of the nodes on the network. The RIO head processor grounds the cable system, but if the cable is disconnected, that earth ground connection is removed. An optional Modicon 60-0545-000 Ground Block at the head will provide earth ground connection when the cable and RIO processor are disconnected. Ground blocks may also be used at other ground points along the trunk cable, as required.

**Note** Local building codes may require that the cable shield be tied to earth ground whenever the cable system exits and/or enters a new building (NEC Article 820-33).

Ground blocks have a low insertion loss, and they usually are not figured into the attenuation calculations unless five or more are used—in that case, calculate an extra .2 dB into the trunk attenuation. The ground block has a 75  $\Omega$  impedance, a return loss of >40 dB, and a wide application frequency range. The 60-0545-000 Ground Block consists of two female in-line F connectors and a separate screw hole binding for attaching a ground wire. The grounding block has two mounting holes, allowing it to be mounted to a flat surface. Two styles of 60-0545-000 Ground Blocks are available and may be used interchangeably. Their mounting dimensions are different:

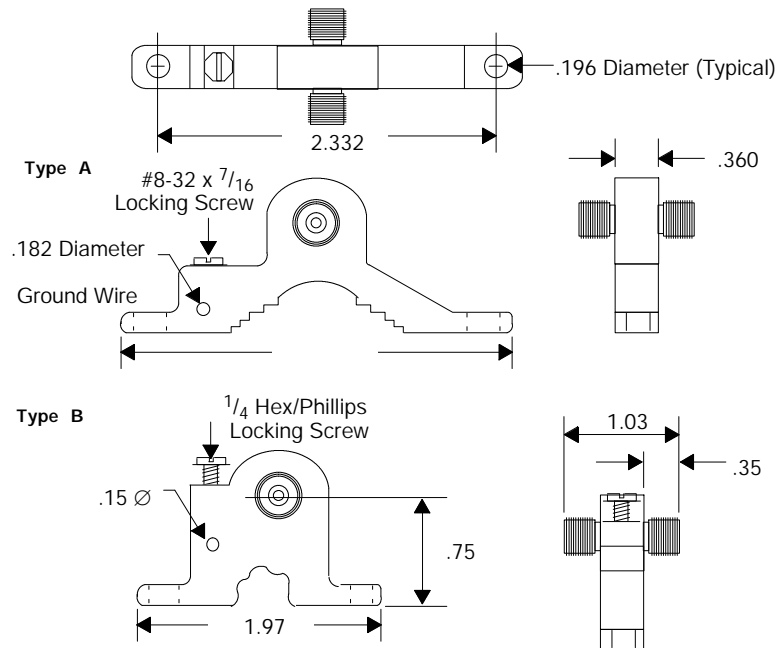

## 3.14 Surge Suppressors

A special ground block with a gas-filled surge suppressor is available for outside installations or any other installations where the cable is exposed to lightning. Surge suppressors have a very low insertion loss, and they usually are not figured into the attenuation calculations unless five or more are used—in that case, calculate an extra .2 dB into the trunk attenuation. A surge suppressor has a  $75 \Omega$  impedance, a return loss of  $>40$  dB, and has a wide application frequency range.

There are two types of surge suppressors—an F connector version and a semi-rigid cable connector version:

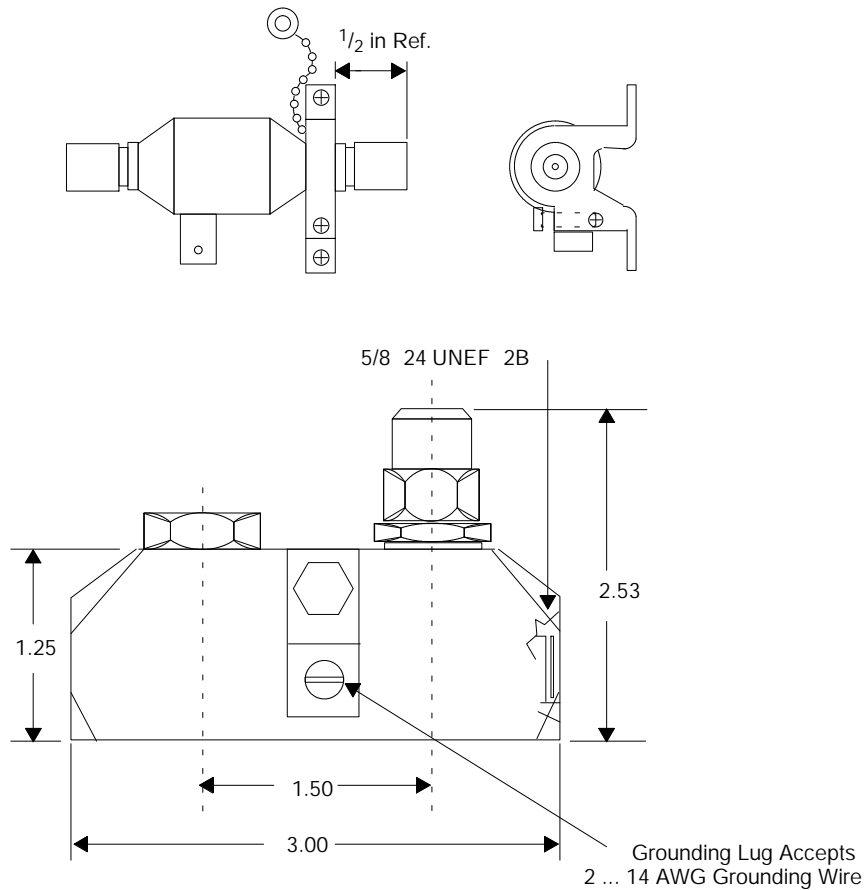

Gilbert Engineering offers a 6003-1 F Connector Surge Suppressor and a 5886-1 Semirigid Cable Surge Suppressor.

### 3.15 Cable Waterproofing Materials

---

Several materials are available to seal and waterproof the cable system when used in a wet, outdoor, or corrosive environment. These materials include sealing boots for F connectors and waterproofing strips to apply over connections.

Modicon 99-0181-000 Environmental Sealing Tape can be used to seal connections. Other materials are available from CATV equipment manufacturers. The types of material offered vary with each manufacturer. Another source for some of these environmental materials is Raychem Corporation.

### 3.16 Fiber Optic Repeater

The 490NRP954 Fiber Optic Repeater provides communication between two or more RIO nodes or segments of networks over the fiber optic medium. Each repeater contains one electrical RIO interface and two fiber optic transceivers.

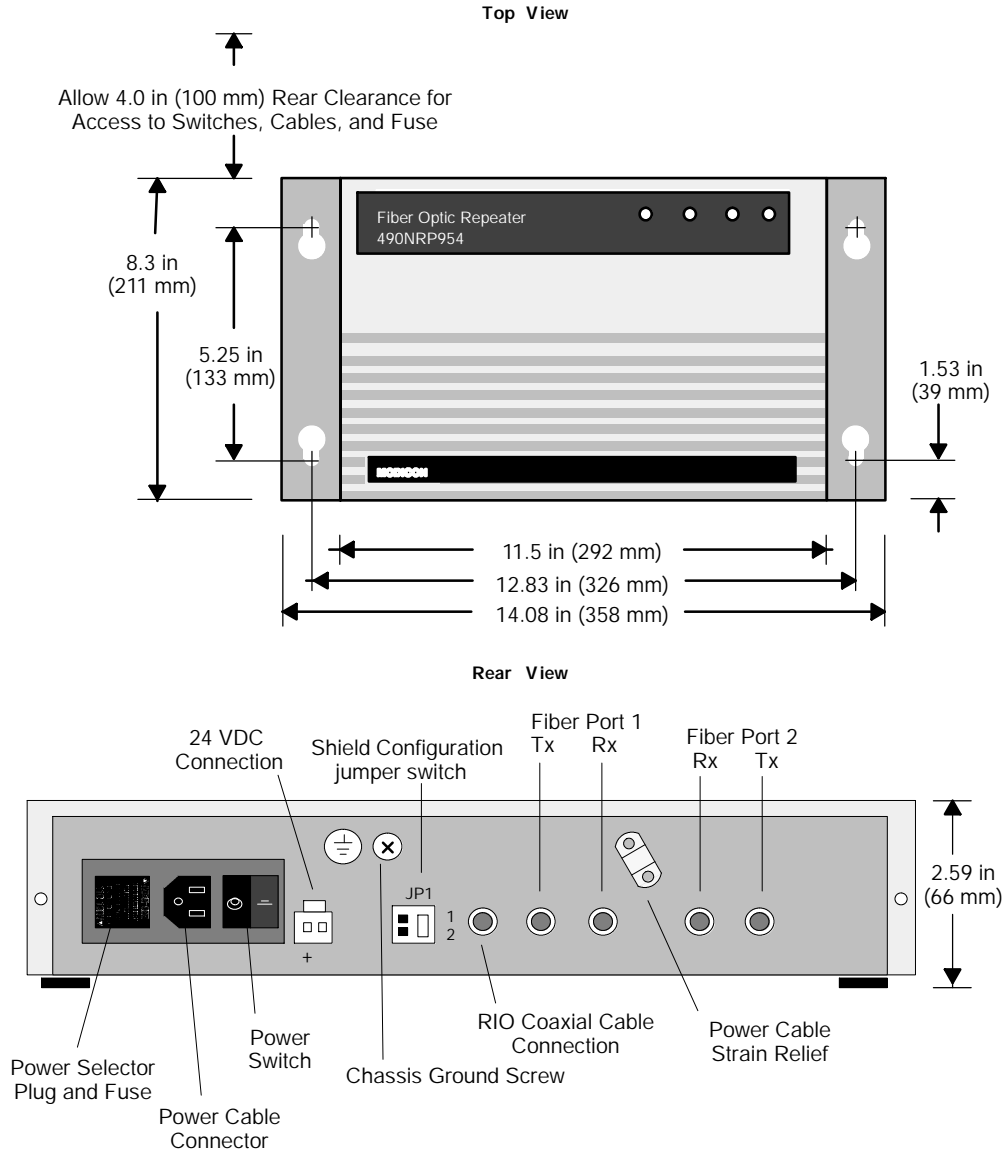

### 3.16.1 Repeater Indicator LEDs

The repeater has a set of LEDs located on the top of the unit:



- The **power OK** LED illuminates steadily when the Repeater has normal power from the AC line or DC source and its internal power supply is operating normally
- The **remote I/O port** LED lights when a signal is received at the RIO port
- Each **fiber port** LED lights when a signal is received at the fiber Rx port

If a port LED fails to illuminate, it can indicate a lack of transmitted signal at another network node. Before replacing a repeater, check the cable connections on the rear panel for a possible incorrect or loose connection. Also check the indicators on other devices on the signal path to see if the signal loss is external to the repeater.

### 3.16.2 RIO Shield-to-Chassis Jumper

The RIO cable shield-to-chassis jumper switch on the rear of the repeater is used to specify the repeater's relationship to chassis ground.

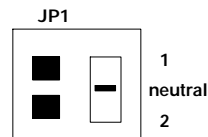

It is shipped in the **neutral** position—i.e., with the switch midway between position **1** and **2**. The jumper can be placed in either the **1** or **2** position if the repeater is being configured as a *head* repeater on the optical link such that:

- In the **1** position, the RIO cable shield is *isolated* from chassis ground by a capacitor—i.e., if low-frequency noise is a problem
- In the **2** position, the RIO cable shield is *connected* directly to chassis ground—i.e., the same ground as the main RIO head processor
- In the **neutral** position, the repeater is configured as a *drop* on the optical link

In a point-to-point optical connection, one repeater is always the head and the other is always the drop:

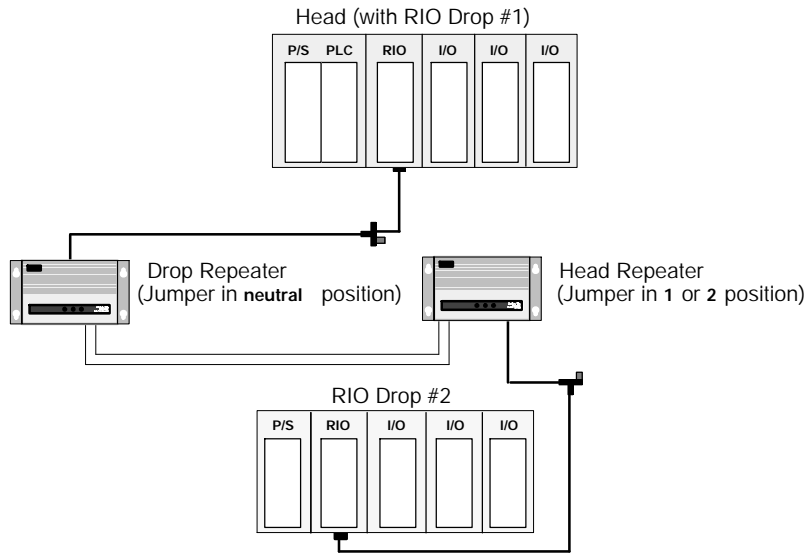

In an optical bus connection, one repeater is always the drop and all other repeaters are heads:

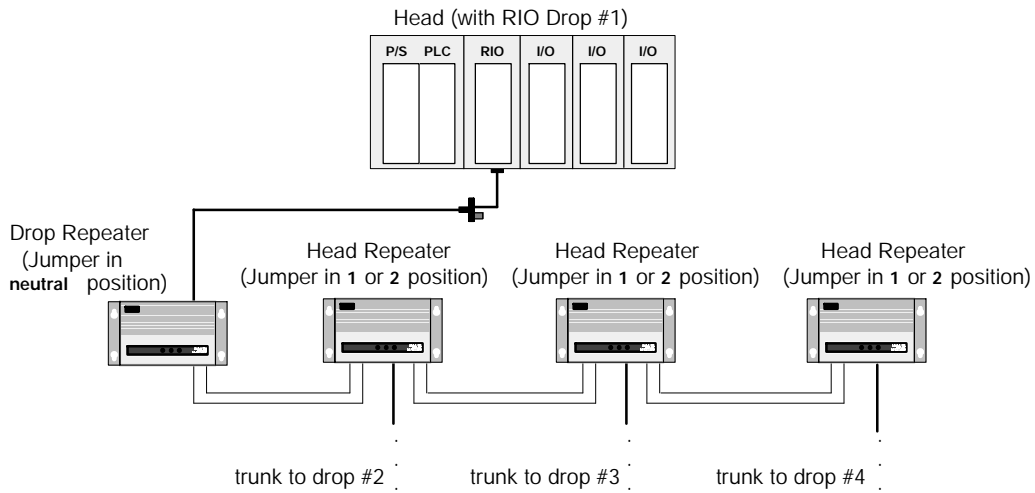

## 3.17 Recommended Materials for Fiber Optic Links

---

Modicon does not manufacture fiber optic products such as cables, connectors, or special tools. However, we have experience with third party suppliers of materials and can give some guidelines on what will work with our products.

### 3.17.1 Connectors

Connector Type	Part Number	Operating Temperature
ST Bayonet (Epoxy)	3M 6105	40 ... +80° C
ST Bayonet (Hot Melt)	3M 6100	40 ... +60° C
Push-Pull ST (Epoxy)	3M 6102	40 ... +80° C
ST Bayonet (Epoxy)	AMP 501380 Series	30 ... +70° C
ST Cleave and Crimp	AMP 504034 Series	40 ... + 65° C
Mechanical Line Splice (one size fits all)	3M 2529 Fiberlok1 II	40 ... +80°

### 3.17.2 Termination Kits

Kit Type	Part Number	Description
Bayonet or Push-Pull ST (Epoxy)	3M 8154	110 or 220 VAC, only for 3M connectors
Bayonet or Push-Pull ST (Hot Melt)	3M 6150	110 or 220 VAC, only for 3M connectors
Bayonet ST (Epoxy)	AMP 501258-7	110 VAC, only for AMP connectors
Bayonet ST (Epoxy)	AMP 501258-8	220 VAC, only for AMP connectors
Mechanical Line Splice	3M 2530	Fiber Splice Prep Kit, complete with cleaving tool

### 3.17.3 Passive Couplers

The AMP Model 95010-4 is a pig tail option and must be used with an enclosure (use AMP Model 502402-4, a 19 in rack-mount enclosure, 1.7 in high).



### 3.17.4 Other Tools

Product	Part Number	Description/Use
3M (Photodyne) Optical Source Driver	9XT	Hand-held optical source driver (requires a light source)
3M (Photodyne) Optical Light Source	1700-0850-T	850 nm Light Source, ST Connectors for 9XT
3M (Photodyne) Power Meter	17XTA-2041	Hand-held Fiber Optic Power Meter
3M Optical Light Source, 660 nm, visible	7XE-0660-J	Use with 9XT to troubleshoot raw fiber, requires FC/ST patch cord
3M FC/ST Patch Cord	BANAV-FS-0001	Connects FC connector on 7XE to ST
3M Bare Fiber Adapter, ST-compatible	8194	Permits use of above source and meter to test raw fiber (two required)

# Chapter 4

## Installing an RIO Network

---

- Installation Overview
- RG-6 Cable Connections
- RG-6 Installation Tools
- Preparing RG-6 Cable for a Connector
- Installing F Connectors on Quad Shield RG-6 Cable
- Installing F Connectors on Non-quad Shield RG-6 Cable
- Installing BNC or Self-terminating F Connectors on RG-6
- Making RG-11 F Connections
- The RG-11 Installation Tool
- Preparing an RG-11 Cable for a Connector
- Installing F Connectors on RG-11 Cable
- Providing Line Termination on the Drop Cable
- Connecting/Disconnecting a Drop Cable at a Tap
- Installing Fiber Optic Repeaters
- Terminating the Trunk Cable
- Installing the Ground Point

## 4.1 Installation Overview

---

This Chapter presents cable preparation and installation procedures for RG-6 and RG-11 flexible cables. The connectors and special-purpose installation tools required for these cables are available Modicon.

Modicon provides a common family of compatible connectors for RG-6 and RG-11 cables. A set of installation procedures has been established, with a common set up procedure and separate finishing procedures for each type of connector used.



**Note** Because of the wide variety of semirigid cables available and because Modicon does not stock any of these cable types, installation procedures for semirigid cable are not presented here. If you choose to use semirigid cable in your installation, contact Modicon Customer Service—(508) 975-9479—and your cable manufacturer for detailed cable installation procedures.

## 4.2 RG-6 Cable Connections

---

Seven types of connectors are available for RG-6 cable:

Connector	Type	Cable Design	Crimp Size
MA-0329-001	F	Quad	.360
MA-0329-002	F	Non-quad	.360
52-0400-000	F (sealing boots)	Non-quad	No Crimp
52-0401-000	F	Any	No Crimp
52-0487-000	BNC	Non-quad	324
043509446	BNC	Quad	.360
52-0399-000	Self-terminating F	Non-quad	324
52-0411-000	Self-terminating F	Quad	.360

### 4.2.1 Installation Tools

The main cause of RIO failure is improper installation of connectors. Modicon provides a set of installation tools that are mandatory for making connections on the RIO cable system. They make the job of connector installation easy, uncomplicated, and reliable. Three tools are required for all RG-6 connectors:

- The Modicon 60-0558-000 Cable Cutters
- The Modicon 60-0528-000 RG-6 Installation Tool with blade pack
- A standard  $7/16$  in open-end wrench

Two other tools are required for certain RG-6 connections:

- A  $7/16$  in torque wrench for non-quad shield F connectors
- A Modicon 60-0544-000 Crimp Tool for quad shield F connectors, an 043509432 Crimp Tool for BNC connectors, and all self-terminating F adapters



**Note** If you purchase premade drop cables from Modicon, you may not need the Modicon RG-6 installation tool or the crimp tool for installation purposes, but we recommend that you have it for maintenance.

## 4.3 RG-6 Installation Tools

---

### 4.3.1 RG-6 Cable Installation Tool

A Modicon 60-0528-000 RG-6 Installation Tool is used to strip any type of RG-6 cable for installation of F connectors. There are two blades on the tool. The first is designed to cut through the cable to the center conductor, cutting away the jacket, the shields, and the dielectric. The second blade is designed to cut off only the jacket, leaving as much braid as possible under it.

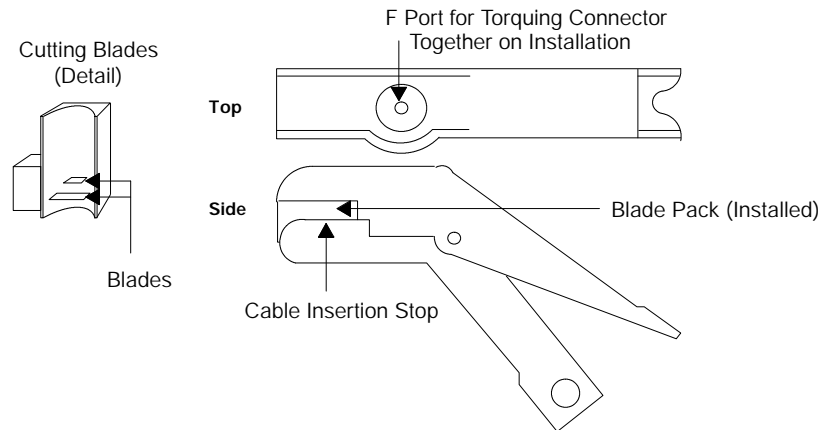

#### Replacement Blade Packs

The blades on the RG-6 installation tool get dull after several hundred uses. A Modicon 60-0529-000 Replacement Blade Pack is available. RG-6 blade packs are color coded red.

### 4.3.2 Crimp Tools

The Modicon 60-0544-000 Crimp Tool is used to install the quad and non-quad shield F connectors and self-terminating F adapters onto RG-6 cable. The tool makes two sizes of hex crimp: 0.324 in and 0.360 in.

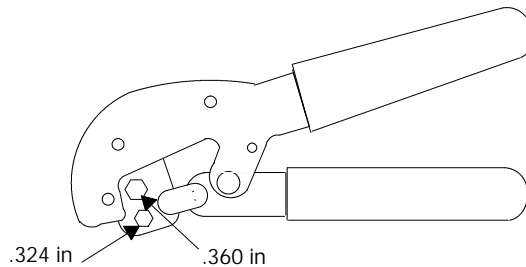

The Modicon 043509432 Crimp Tool is used to install BNC connectors onto RG-6 cable. The tool makes two sizes of hex crimp: 0.276 and 0.325 in.

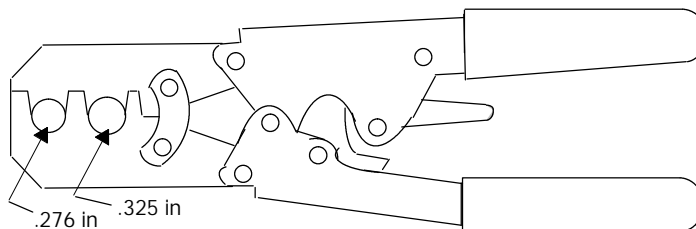

### 4.3.3 Cable Cutters

Modicon 60-0558-000 Cable Cutters are used to cut cable without compressing it. The cable cutters have a high leverage handle and rounded cutting edges. Cable cut with normal flat diagonal cutters will flatten, and this will alter the cable's impedance.



## 4.4 Preparing RG-6 Cable for a Connector

---

 **Note** If you are using dual or messengered cable, remove the rib before preparing the cable.

**Step 1** Cut the cable squarely across the end with the 60-0558-000 Cable Cutters. Open the jaws of the 60-0528-000 RG-6 Installation Tool and set the cable in the V-groove with the cable end placed against the stop.

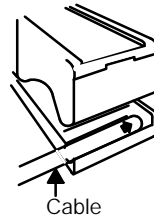

**Step 2** Release the handle and let the spring hold the tool on the cable. Rotate the stripper clockwise with your index finger on the handle until the tool turns freely. Let the spring provide the cutting pressure. The number of turns depends on the number of cable shields—dual shields require fewer turns than quad shields.

 **Note** Adjust the number of rotations so that the second blade cuts as little of the braid as possible. When the crackling noise stops, the first blade has cut through the shields. Apply pressure to the tool and rotate it one more time to cut through the remaining dielectric, then pull off the cut cable. This method usually saves braid.

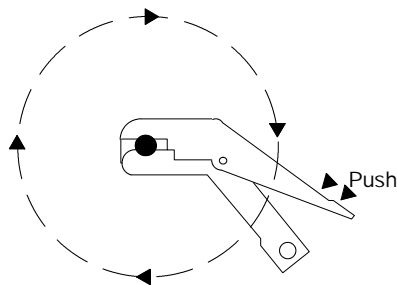

- Step 3** If the cable is not fully stripped, squeeze the jaws of the tool together with your thumb and forefinger. Using light pressure, make one or two revolutions of the tool around the cable until the tool cuts through the cable jacket.

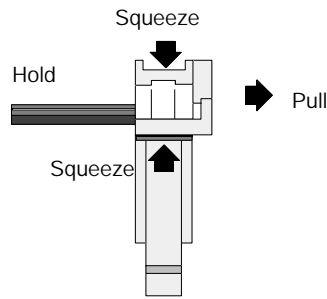

- Step 4** Open the jaws and remove the cable. The dielectric plug and  $\frac{1}{8}$  in of the outer cable jacket should be cut from the cable. Remove any long braid strands remaining around the prepared cable end. (Long braid strands may indicate that a new blade pack is needed.) Remove any dielectric on the exposed center conductor.



- Step 5** Fold all of the shield over the jacket except the inner bonded foil. Avoid tearing the inner cable foil.

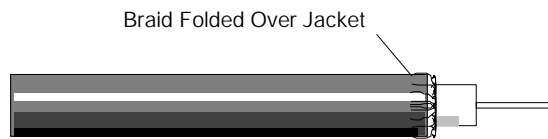

Once this cable preparation procedure is completed, you are ready to install RG-6 connectors and/or adapters on the cable.



## 4.5 Installing F Connectors on Quad Shield RG-6 Cable

---

 **Note** Use an F connector from an MA-0329-001 Cassette on an RG-6 quad shield cable prepared according to the procedure described in Section 4.4.

**Step 1** Place the cable against the side of an F connector, aligning the end of the jacket with the bottom of the crimp ring. Mark the cable jacket at the top of the crimp ring.

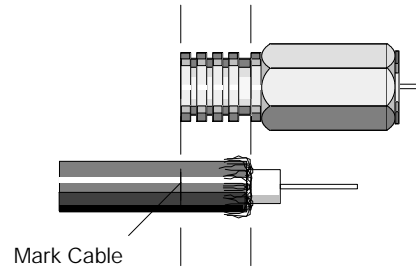

**Step 2** Using a twisting motion, push the cable firmly into the end of the F connector in the MA-0329-001 Cassette until the cable mark lines up with the end of the crimp ring.

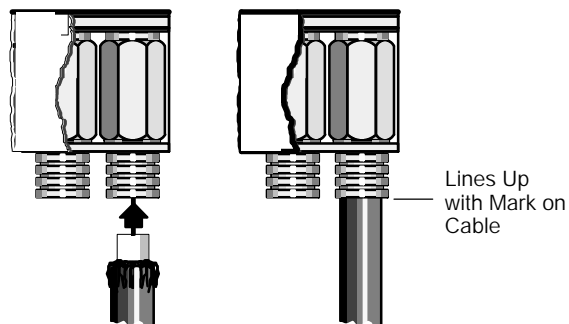

**Step 3** Remove the F connector by sliding it out the side of the cassette.

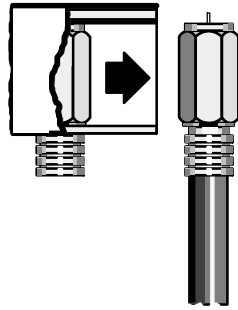

**Step 4** Align the 60-0544-000 Crimp Tool on the F connector, and apply a .360 in crimp.

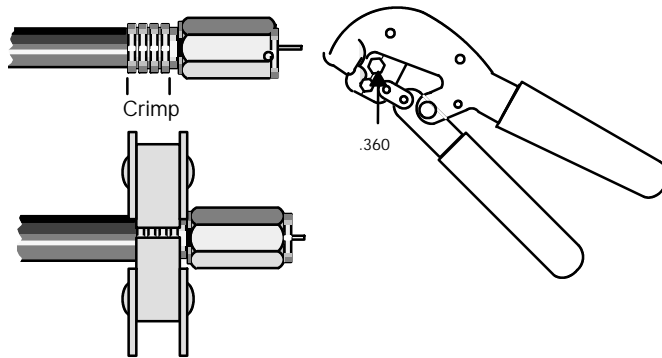

**Step 5** Pull on the F connector to make sure that the crimp is snug—the connector should not fall off.

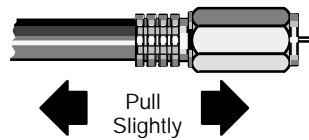

**Step 6** Install the F connector onto the cable port of the RIO drop adapter, tap, or other cable hardware device using a  $\frac{7}{16}$  in open-end wrench.

 **Note** Finger tightening is not sufficient.

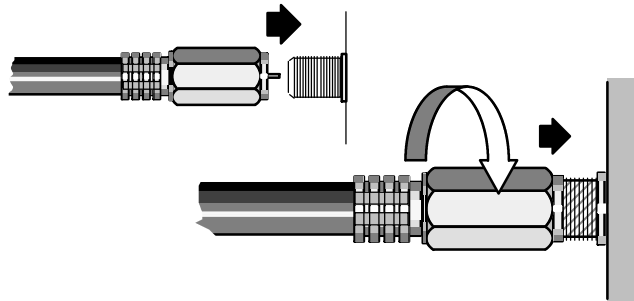

## 4.6 Installing F Connectors on Non-quad Shield RG-6 Cable

---

 **Note** Use an MA-0329-002 or 52-0400-000 F connector from a Cassette on an RG-6 non-quad shield cable prepared according to the procedure described in Section 4.4.

**Step 1** Using a twisting motion, push the cable firmly into the end of the F connector in the Cassette until the cable dielectric is flush with the end of the mandrel.

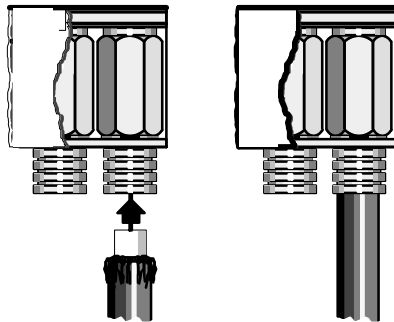

**Step 2** Remove the F connector by sliding it out the side of the cassette.

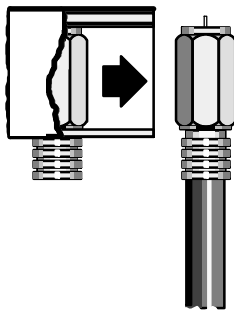

- Step 3** Visually inspect the cable insertion depth by looking into the end of the F connector—the white dielectric should be flush with the end of the mandrel.

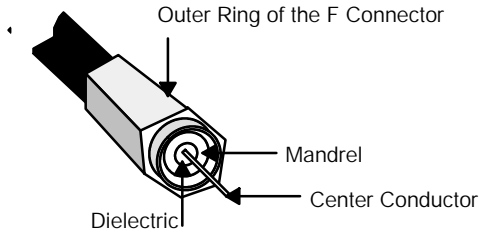

- Step 4** Tighten the F connector nut onto the 60-0528-000 RG-6 Installation Tool connector with a  $\frac{7}{16}$  in torque wrench to 47 ... 57 in/lb of torque. Then pull on the cable to test the integrity of the connection. If the cable pulls out of the connector, begin the procedure again.

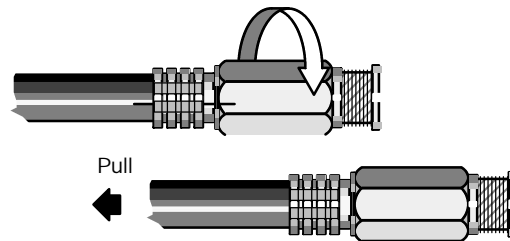

- Step 5** If the connection holds, disconnect the F connector from the tool and install it onto the cable port of the RIO drop adapter, tap, or other cable hardware device using a  $\frac{7}{16}$  in open-end wrench.

 **Note** Finger tightening is not sufficient.

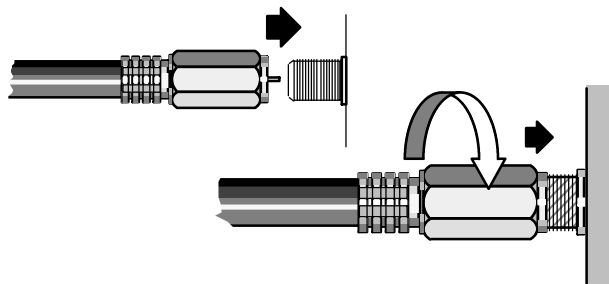

## 4.7 Installing BNC or Self-terminating F Connectors on RG-6 Cable

---

The following procedure may be used to install either a BNC connector or a self-terminating F adapter on an RG-6 cable. The BNC connector and self-terminating F adapter are available in two versions that fit non-quad shield and quad shield cable. Make sure you are using the proper size connector for the cable:

Connector Type	Cable Type	Connector Part #	Crimp Size
BNC	Non-quad	52-0487-000	0.324
BNC	Quad	043509446	0.360
Self-terminating F	Non-quad	52-0399-000	0.324
Self-terminating F	Quad	52-0411-000	0.360

- Step 1** Strip the end of the cable jacket by a maximum of 0.375 in and gently flare the cable shield, exposing the cable's center conductor. Slip a crimp ferrule onto the cable as shown below.

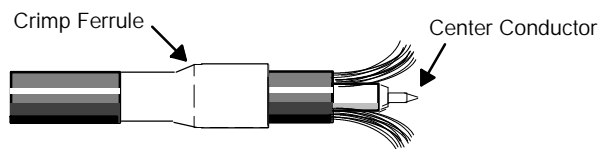

- Step 2** Insert the cable center conductor into the stem of the connector, pushing firmly to enter the spring clip of the pin. The cable insulator should seat on the connector insulator. Distribute the cable shield evenly around the outside of the connector collar.

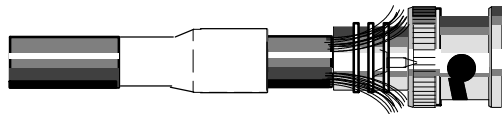

**Step 3** Work the ferrule over the shield braid onto the connector collar. Then crimp with the 043509432 tool.

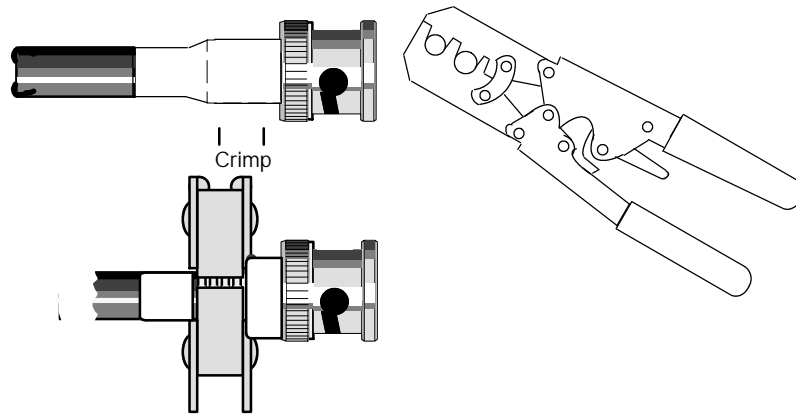

## 4.8 Making RG-11 F Connections

---

To make a connection to an RG-11 cable, use an F connector from a Modicon 52-0401-000 cassette with sealing boots.

### 4.8.1 Required Tools

The following tools are required to install an F connector on an RG-11 cable:

- The Modicon 60-0530-000 RG-11 Installation Tool with gray blade pack
- The Modicon 60-0558-000 cable cutters (see page 95)
- A standard  $\frac{5}{8}$  in open-end wrench
- A  $\frac{5}{8}$  in torque wrench

The torque wrench is recommended for initial installation—the F connector should be installed using the required torque. After judging and applying the proper torque, a standard open-end wrench may be used for maintenance.



## 4.9 The RG-11 Installation Tool

---

The Modicon 60-0530-000 RG-11 Installation Tool is used to strip any type of RG-11 cable for installation of F connectors. There are two blades on the installation tool. The first is designed to cut through the cable to the center conductor, cutting away the jacket, the shields, and the dielectric. The second blade is designed to cut off only the jacket, leaving as much braid as possible under it.

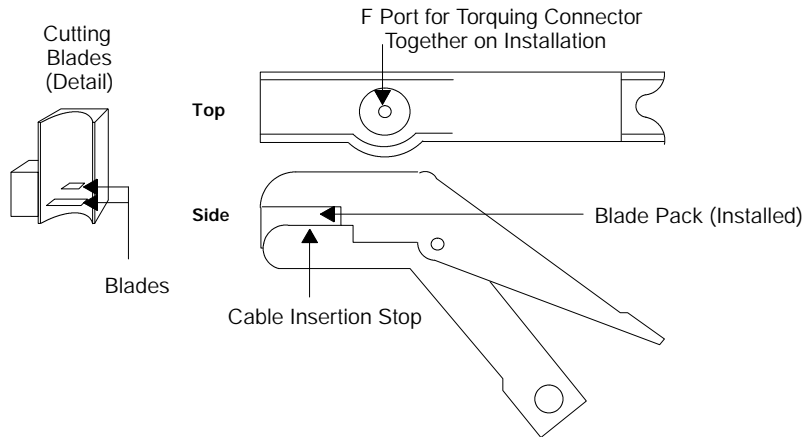

Make adjustments in the number of rotations so that the second blade cuts as little of the braid as possible. Usually the first blade has cut through the shields when the crackling noise stops. Apply some pressure to the tool while rotating it once more after the crackling stops to cut through the remaining dielectric, then pull off the cut cable. This method usually saves as much braid as possible.

### 4.9.1 Replacement Blade Packs

The blades on the RG-11 installation tool get dull after several hundred uses. A Modicon 60-0531-000 Replacement Blade Pack is available. RG-11 blade packs are color coded gray.

## 4.10 Preparing an RG-11 Cable for a Connector

---

- Step 1** Cut the cable squarely across the end with the 60-0558-000 Cable Cutters. Open the jaws of 60-0530-000 Installation Tool and set the cable in the V-groove with the cable end placed lightly against the stop.

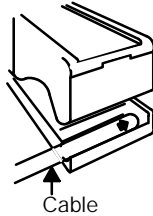

- Step 2** Release the tool handle and let the spring hold the tool on the cable. Slowly rotate the stripper on the tool handle clockwise with your index finger until the tool turns freely. Let the spring provide the cutting pressure. The number of turns depends on the number of cable shields.

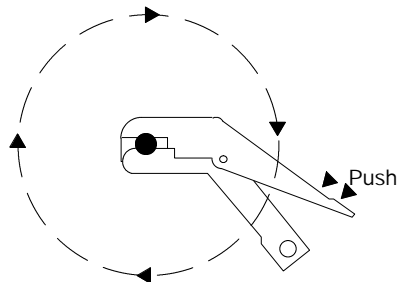

- Step 3** If the cable is not fully stripped, squeeze the jaws of the tool together with your thumb and forefinger. Using slight pressure, make one or two revolutions around the cable to cut through the cable jacket.

- Step 4** Mark the cable jacket on the side of the tool where the cable exits—this mark shows the connector's insertion depth.

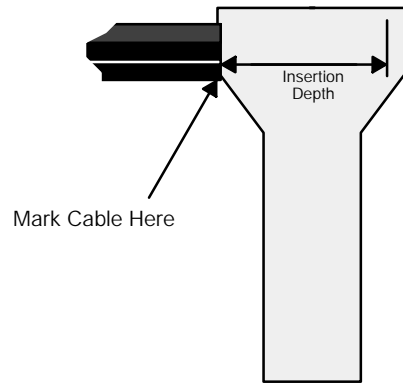

- Step 5** Open the jaws and remove the cable. Twist off the cable dielectric and jacket by hand. Remove any long braid strands remaining around the prepared cable end. Long braid strands may be an indication that a new blade pack is needed. Remove any dielectric on the exposed center conductor.



- Step 6** Fold all of the braid over the jacket. Avoid tearing the inner foil. To make insertion into the connector easier, slightly squeeze the cut end of the foil-covered dielectric.

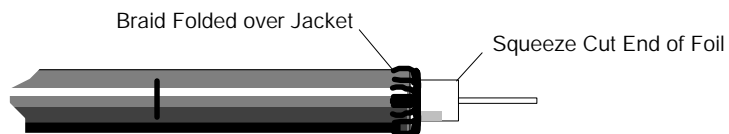

## 4.1.1 Installing F Connectors on RG-11 Cable

---

 **Note** Use an F connector from a Modicon 52-0401-000 cassette (six connectors per cassette), and prepare the cable according to the procedure described in Section 4.10.

**Step 1** Push the cable into the end of the connector in the 52-0401-000 cassette until the foil-covered dielectric is inside the tubular part of the connector.

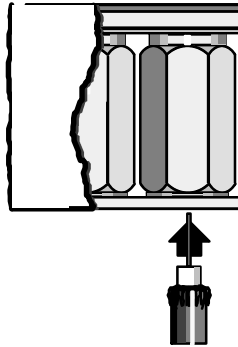

**Step 2** Press the cable hard and twist slightly until it is fully inserted in the connector. The insertion depth mark on the cable jacket should be even with the end of the connector.

**Step 3** Pull lightly on the cable to be sure that the center conductor has been seized. If the cable pulls out of the connector, start the procedure over again. When the cable has been secured properly in the connector, remove the connector by sliding it out the side of the cassette.

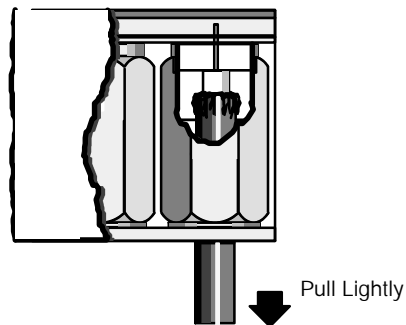

- Step 4** Hand tighten the 52-0401-000 connector onto the installation tool connector. Hold the cable immediately behind the F connector and tighten the connector nut with a  $\frac{5}{8}$  in torque wrench. Make sure the nut is tightened between 45 ... 57 in/lb of torque, usually 7 ... 8 turns, although more turns may be necessary.

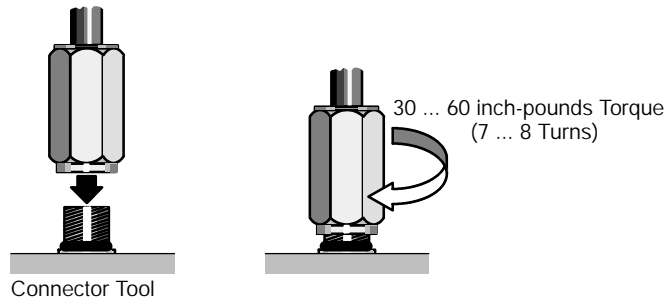

- Step 5** Twist the cable directly behind the F connector. If the cable turns, apply more torque until no movement is observed. If the F connector has been completely torqued and/or bottomed out and the cable still twists, start the procedure over using another F connector in the 52-0401-000 cassette.

 **Note** The insertion mark on the cable will be flush with the edge of the connector only when the F connector is not connected to another device and the connector nut is pulled back.

- Step 6** Tug on the cable. If the cable pulls out, the installation is faulty and the procedure must be repeated using a new connector.

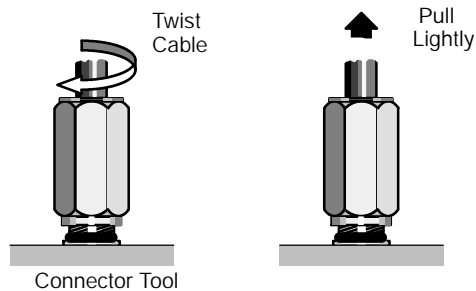

- Step 7** Disconnect the F connector from the installation tool.

- Step 8** Install an F connector sealing boot over the F connector port on the drop adapter or tap. Slide the sealing boot completely over the F connector port until at least the first two threads of the connector are showing.

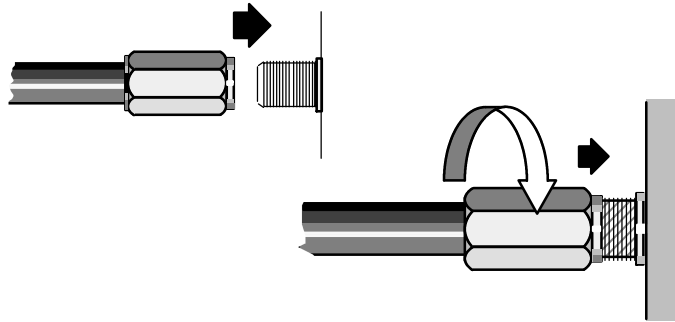

 **Note** Additional protection is recommended for applications involving water-tight applications.

- Step 9** Install the F connector on the drop adapter or tap port. Tighten the connector on the port until finger tight, then another  $\frac{1}{3}$  turn with a  $\frac{5}{8}$  in wrench. The connector must be snug.

## 4.12 Providing Line Termination on the Drop Cable

---

Drop cables running to J890/J892-00x drop adapters or 410 and 3240 Motion modules require Modicon 60-0513-000 In-line BNC Terminators that allow you to disconnect and reconnect the cable.



**Note** The cables should be labeled at every connection to identify each drop and trunk cable segment. All taps should be labeled with a number that corresponds to the drop number specified in the PLC's I/O Map. Instructional labeling at all in-line termination points on the drop cable promotes proper cable connection and disconnect practices.

### 4.12.1 Installing a BNC In-line Terminator on a Drop Cable

Attach a 90° BNC angle connector to the RIO port on the drop adapter, then connect the 60-0513-000 BNC In-line Terminator. Connect the BNC connector on the drop cable to the in-line terminator.

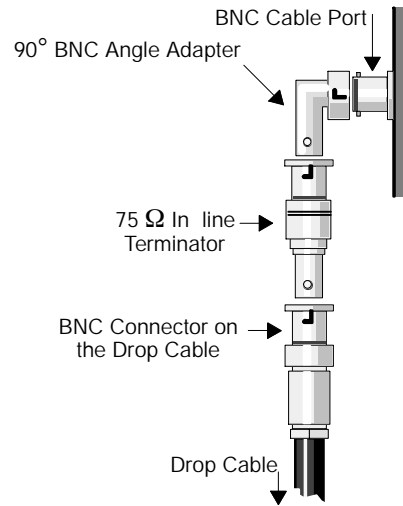

#### 4.12.2 Optional Drop Cable In-line Termination

All drop adapters—except those listed in Section 1.4.4—provide  $75 \Omega$  termination inside the modules themselves. You may want to consider providing the drop cables leading to these adapters with self-terminating F or BNC adapters to assure proper cable termination when the drop adapter is disconnected.

Modicon 52-0370-000 Self-terminating BNC Adapters, which are standard in 984 Hot Standby systems, may be used optionally in cases where self-terminating BNC connections are desired. Modicon 52-0411-000 Self-terminating F Adapters may be used for quad shield drop cable, and Modicon 52-0399-000 Self-terminating F Adapters may be used for non-quad shield drop cable.

##### Installing A Self terminating Adapter on a Drop Cable

- Step 1** Cut the drop cable into two sections, one of which is 18 in (45 cm) long. Install an F or BNC connector on each end of the 18 in cable section.
- Step 2** Install an F connector on one end of the longer drop cable section and the self terminating F or BNC adapter on the other end.
- Step 3** Connect the 18 in section of drop cable to the cable port on the RIO drop adapter using the end that has the label attached closer to it (connection point A). Connect the other end of the 18 in section of drop cable to the self-terminating adapter on one end of the longer drop cable (connection point B).

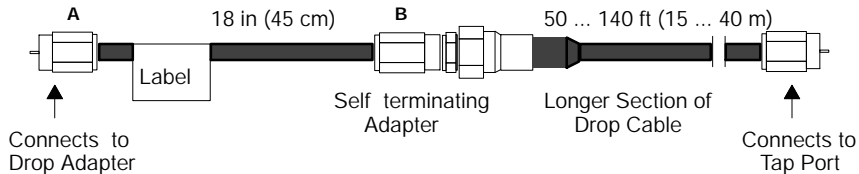

- Step 4** Connect the F connector on the other end of the longer drop cable section to the tap port. The drop connection is now complete.
- Step 5** To disconnect the drop from the network while the network is running, disconnect the 18 in drop cable section from the self terminating adapter (connection point B), then from the drop adapter (connection point A).



## 4.13 Connecting/Disconnecting a Drop Cable at a Tap

---

None of the three ports on an MA-0185-100 Tap can be left open while the system is running. Taps that do not have drop cables running from them must be terminated with a Modicon 52-0402-000 Tap Port Terminator.

### Connecting A Drop Cable To An Unused Tap

- Step 1** Obtain permission from your network manager to stop communications on the network.
- Step 2** Disconnect the 52-0402-000 Tap Port Terminator from the drop cable tap port where you want to connect the drop cable.

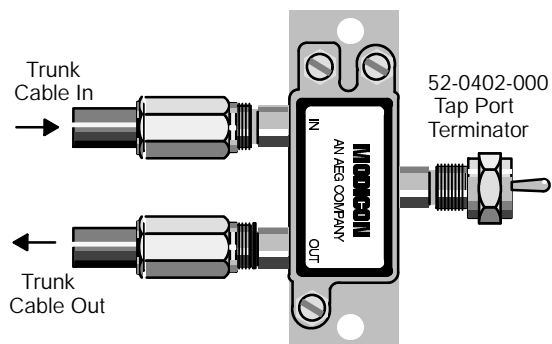

- Step 3** Connect the F connector on the drop cable to the drop-cable tap port.

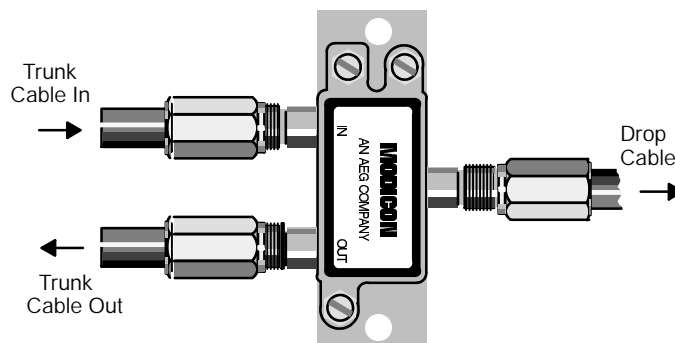

### **Disconnecting A Drop Cable From A Tap**

- Step 1** Obtain permission from your network manager to stop communications on the network.
- Step 2** Disconnect the F connector on the drop cable from the drop-cable tap port.
- Step 3** Insert a Modicon 52-0402-000 Tap Port Terminator terminator in the drop-cable tap port.



**Caution** Do not connect a drop cable to or disconnect a drop cable from a tap on an ACTIVE network. Either of these two actions can cause excessive communications errors on the network.

## 4.14 Installing Fiber Optic Repeaters

---

Prior to installing 490NRP954 Fiber Optic Repeaters, fiber optic cable must be installed. Follow the cable manufacturer's recommendations for routing, installation, and testing of the cable. Take care when terminating the ends of each fiber optic cable in order to minimize loss of the optical signal. Follow the manufacturer's guidelines for installing optical connectors. Test the cable for proper attenuation prior to the connection of the fiber optic repeaters.

The cable ends should be accessible at each fiber optic installation site. Allow sufficient cable length for a service loop and strain reliefs. Label each cable end to facilitate future maintenance.



**Caution** The RIO network must be powered OFF before installing or replacing a fiber optic repeater .

### 4.14.1 Mounting a Repeater

The 490NRP954 Repeater's bottom surface is fitted with pads. Brackets for bolting the unit to a vertical panel are also provided. Your choice of horizontal or vertical mounting should provide access to the device for observing the LED indicators on the front panel and to the rear panel connectors for ease of installation and future servicing.

#### **Horizontal Mounting**

To mount the unit on a horizontal surface, place it at or below eye level to allow viewing the network indicators. Secure it to the surface to prevent it from shifting its position. Do not allow the unit to pull or strain on the network cables and power cable. The mounting brackets supplied with the unit for vertical panel mounting can also be used to secure the unit on a horizontal surface.

#### **Vertical Mounting**

For vertical mounting, use the brackets supplied with the unit for bolting to a panel. The brackets have tabs that insert into slots on the repeater's bottom panel. No additional hardware is required for securing the brackets. You will have to furnish hardware for bolting the repeater brackets to your panel—four bolts are required. Typically, standard 1/4-20 (10 mm) bolts are satisfactory.

The repeater's indicators will usually be readable at or slightly above eye level when the unit is installed in the vertical position.

#### 4.14.2 Connecting the Network Cables

The fiber optic cables should already be run to the site, with connectors installed. If they are not in place, install them using the manufacturer's installation guidelines. Each cable should be labeled to identify the transmit/receive link to which it connects.

Connect the RIO coaxial cable and the fiber optic cables to the repeater's rear panel connectors. Secure the coaxial cable to the F-connector.

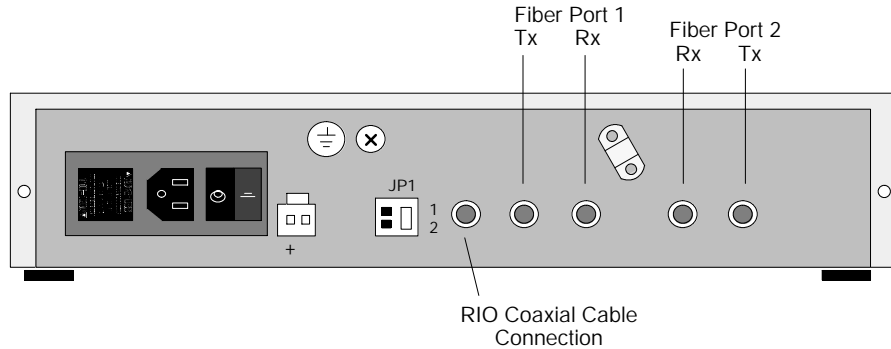

If the network links are active, the **remote I/O** and **fiber port** LEDs on the front panel of the unit will be in a steady ON state, indicating that receive activity is under way (see Section 3.16.1 on page 86 for details).



**Warning** Do not view the ends of fiber optic cable under magnification while a transmit signal is present on the cable—severe eye damage may result. Use white light only!

#### 4.14.3 RIO Shield-to-Chassis Jumper

Set the shield-to-ground jumper switch appropriately to specify the repeater's relationship to chassis ground (see Section 3.16.2 on page 86 for details).

#### 4.14.4 Connecting Power

The repeater operates either from 110/220 VAC line power or from 24 VDC. The AC and DC power connections are located on the back of the panel.

##### Connecting AC Power

The repeater is supplied with an AC power cable 6 ft (2 m) long for use with either 110/120 VAC or 220/240 VAC single-phase power. The power cable

connects to a socket on the rear panel. Grounding is supplied through the power cable. The AC power cable is keyed for North American 110/120 VAC power outlets. If necessary, install a different plug on the cable for the power source at your site.

Turn the power switch OFF and remove the AC power cable from the repeater. Set the power selector plug to the 110/120 VAC or 220/240 VAC position for the power source at your site. To do this, remove the power selector plug by prying under its tab with a small screwdriver. Set the plug to the proper voltage position as shown on the plug body, then reinsert it. Insert the power cable into the rear panel connector. Secure the power cable under the strain relief. Plug the cable into the AC power source.

### Connecting DC Power

Your DC power source must supply 1 A at 24 V. Switch the DC source OFF. Connect the source to DC power terminals, observing the proper polarity. Secure the power wiring under the strain relief.

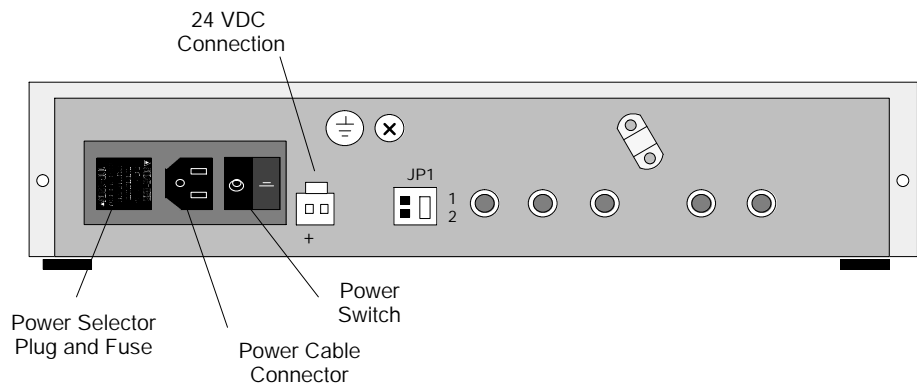

**Caution** Fiber optic repeaters cannot be operated with both 115 VAC and 24 VDC power applied at the same time.

### Grounding

The repeater obtains its ground in the AC power cord via the green **gnd** wire or through the DC wire. Using a continuity tester, verify the repeater chassis is grounded to the site ground. To ensure proper grounding, connect the chassis ground to the site ground by direct chassis to ground connection.

### Applying AC Power

If you are using AC line power, reapply AC to the fiber optic drop site. The main power switch controls the power to the unit. Set the power switch to the I (ON) position. The unit's **power OK** LED will illuminate.

**Applying DC Power**

If you are using DC power, switch on your DC to the repeater. The unit's **power OK** LED will illuminate.



**Caution** When DC power is used, the **POWER** switch on the unit is disabled. Power is supplied to the unit when source power is activated. Under DC power, the unit does not provide surge protection.

## 4.15 Terminating the Trunk Cable

---

The trunk cable must be terminated by inserting a Modicon 52-0422-000 Trunk Terminator in the trunk-out port of the last tap on the RIO network:

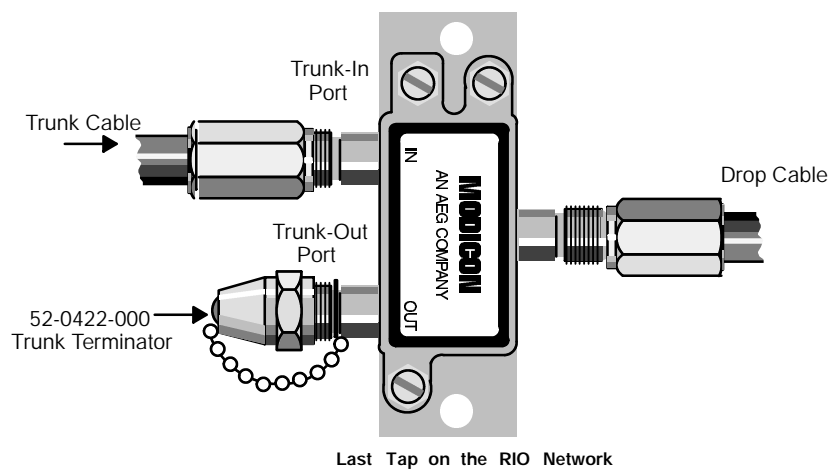

## 4.16 Installing the Ground Point

---

The cable system should be grounded at a point within 20 ft of the RIO processor at the head-end of the network. A ground block, a single Modicon MA-0185-100 Tap, a Modicon MA-0186-100 Splitter, or an optional Modicon 60-0545-000 Ground Block may be used, assuring that the cable system will be permanently grounded even when disconnected from the RIO processor.



**Note** Do not disconnect the cable system from the central ground point—disconnecting the system from ground will create an unfavorable floating ground condition.

A screw is provided on taps, splitters, and ground blocks as the grounding point. If you use a ground block, mount it in a small enclosure.

To install a 60-0545-000 Ground Block:

- Cut the cable
- Install two F connectors on the cable
- Attach two F connectors to the ground block
- Wire the ground block to an appropriate ground (typically building steel)



# Chapter 5

## Testing and Maintaining an RIO Network

---

- Maintenance and Testing Requirements
- RIO System Tests
- Problem Sources on an RIO Network
- On-line and Off-line Error Isolation
- Troubleshooting Fiber Optic Repeaters

## 5.1 Maintenance and Testing Requirements

---

A properly installed RIO system will achieve reliable communications between the nodes with the certainty that timing and integrity are consistent and repeatable. After the installation has been completed, the RIO network must be tested to ensure proper operation of all network components. Each test should be documented to provide data for ongoing maintenance.

### 5.1.1 Documenting Drop Maintenance Information

A maintenance information log form (shown on the next page) should be used for documenting key information about the type of RIO adapter used at each drop; the adapter type—e.g., a J890, P892—serial number, revision level (PROM combo), and physical location of the drop can be recorded. If the adapter does not have a PROM combo, the PROM combo field may be used to log the revision of the software or hardware of the particular node.

Before an RIO drop is powered up, a *PROM combo label* with the four-digit number on it should be written beside its location on the topology plan. This will allow quick reference of the option board's firmware revision should it become necessary to replace the PROMs (due to failure or upgrade).

**RIO Drop Maintenance Information Log**

Customer				Network
Location				Plant
Revision/Approved by				Date
<b>Drop Number</b>	<b>Node Type</b>	<b>Serial Number</b>	<b>PROM Combo</b>	<b>Plant Location</b>

## 5.2 RIO System Tests

---

A battery of up to eleven tests can be performed to ensure reliability of the RIO system. These tests are generally performed in the order described below.

### 5.2.1 Fundamental RIO System Tests

Tests 1 ... 7 are the minimum recommended tests for Modicon RIO networks. They can be performed by most customers in the field given the proper test equipment.

#### **Test 1 Pre-installation Cable Test**

Performed while the cable is still on the reel, this test includes includes:

- Attenuation sweep test
- Return loss sweep test
- Attenuation measurements test
- TDR test

Modicon and Comm/Scope cables are pretested and do not need to be retested unless shipping damage is suspected or unless you prefer to test all cable on-site before installation.

#### **Test 2 Visual Inspection**

A check of the entire network including but is not limited to:

- Tap installation
- Cable installation
- Cable routing
- Grounding
- Connector installation

#### **Test 3 Induced Voltage Test**

A check for any potentially hazardous AC voltages on the cable system.

**Test 4 Grounding Test**

A check for potential problems with the cable shields and verify system grounding to a low impedance earth ground.

**Test 5 Oscilloscope Noise Analysis**

Determines the noise level—i.e., whether power spikes are present. Typically the noise level should not exceed 20 mV.

**Test 6 Time Domain Reflectometer (TDR) Test**

Performed on all drop cables and at all trunk end points. It tests the integrity of all drop cables up to and including the tap port, as well as the trunk cable components. Results are produced on a strip chart record with the location of impedance mismatches and the extent of the impedance mismatch. The specification limit for any TDR measurement is determined by the cause of the mismatch.

**Test 7 Attenuation Sweep Test**

Tests the ability of the cable system to pass RIO signals without degradation over the full bandwidth. The test is conducted from the RIO processor node to all trunk and drop end points.

**5.2.2 RIO System Tests for Critical Applications**

Tests 8 ... 10 guarantee performance—if your RIO network is critical to the operation of your process, these tests are highly recommended. They can also be beneficial if your operating environment is extremely noisy.

**Test 8 Attenuation Measurements**

Taken during the attenuation sweep test or using the LMT/LMR attenuation measurement system. This test yields the maximum attenuation on the trunk and on the entire network, end to end. The attenuation should be close to the designed attenuation and must never exceed 35 dB (32 dB for the host-based PLCs).

**Test 9 Return Loss Sweep Test**

A test of reflections on the network. It tests the trunk cable at all end points and at least one drop cable for return loss over the full RIO bandwidth. The return loss on the trunk must be below 16 dB, and below 14 dB on any drop.

**Test 10 Noise Floor Level Test**

Determines the level of noise on the network within the full bandwidth used by RIO. Ensures that the noise floor level is below +10 dBmV over the full RIO bandwidth at any trunk end point and at least one drop cable.

### 5.2.3 Network Startup

The last test should be performed on all startups.

#### Test 11 Network Startup

Tests all the nodes on the network while they are communicating.

Communication error counters are monitored over a given time period.

## 5.3 Problem Sources on an RIO Network

---

Noise on the RIO network is a frequently identified problem source in the troubleshooting process. The symptom is usually excessive retries at the RIO drop adapters. Most noise problems are caused either by inadequate spacing of RIO cable or components from power cables or by an inadequate earth ground. The other common problem source is poor installation.

### 5.3.1 Solving Spacing Problems

Spacing problems can frequently be identified in a visual check on the network. Make sure that a spacing of 12 ... 14 in per kV of power is maintained between the cables and components in your RIO system and any type of low to medium power cable.

We recommend that you avoid all power cable including DC power cables. DC power cables pick up spikes from AC power cables and then induce the spikes onto the RIO cable. Even the low power AC cables can induce spikes onto the RIO cable system.

### 5.3.2 Potential Grounding Problems

A low impedance earth ground is typically hard to measure properly; even after the measurement is performed, it can be misleading. A properly installed Modicon RIO system is grounded at or near (within 20 ft) the RIO processor at the head-end of the network. The only other condition under which you should ground the network is when the cable enters or exits a building (per NEC code).

If the system is not properly grounded, it will produce excessive retries. We recommend that you connect a separate ground wire from the programmable controller directly to plant ground. The wire should minimally be 14 gauge green or bare wire. If the controller is grounded only to the panel, make sure the panel wire is sufficient (typically 2 gauge) to handle the load of the panel and that a separate wire is used to ground the panel. Do not use conduit to ground a controller or panel.

Another prevalent grounding problem is with the equipment connected to the controller. When large motors, drives, or spindles are not properly grounded, they cause an excessive amount of EMI/RFI and conduct this noise onto the power system. EMI/RFI interferences are sometimes misinterpreted as programmable controller problems. You should consult with the manufacturer of these products to ensure that they are properly grounded.

### 5.3.3 Problems Stemming from Poor Installation

Defective media products can account for some system problems. The main installation problem is usually in the connectors. Using recommended connectors and tools will minimize these kinds of problems.

Installation problems can usually be tracked by performing a visual inspection of the network. You should be able to pull on the F or BNC connections without them falling off. Connectors may also need to be tightened onto the device ports.

Defective media products like cable and taps cannot be seen, and need to be tested using the procedures described in Section 5.2.



## 5.4 On-line and Off-line Error Isolation

---

RIO troubleshooting is a process of isolating problems in an *on-line* system, usually with the aid of LED indicator lamps and system statistics.

Media-related problems are generally solved off-line, not by using LEDs or system statistics. However, once a problem has been isolated to its source using any of the off-line tests described in the last chapter, it is sometimes possible to locate the problem source using the on-line troubleshooting procedures discussed below.

For instance, if a network has passed its sweep and TDR tests but has failed its noise floor test, the network can sometimes be brought up to troubleshoot the source of the noise. By using the retry counters, the noise source can be isolated and the problem corrected. Ineffective grounding of external non-Modicon equipment, ineffective grounding of Modicon equipment, or inadequate spacing of coaxial from power cable can be isolated while the network is on-line.

## 5.5 Troubleshooting Fiber Optic Repeaters

Here is a typical point-to-point RIO fiber optic link:

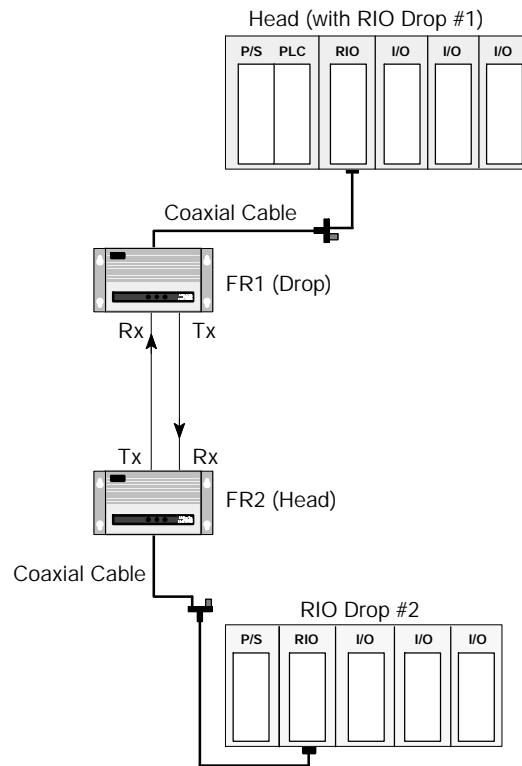

There are well documented procedures for analyzing the wireside characteristics of this type application, and it is recommended they be used as a first line of attack and afterward whenever trouble is suspected.

If the coaxial system is working properly, it will cause the **remote I/O** LED on FR1 to illuminate. If that LED illuminates as expected, then the **fiber port 1** LED on FR2 should illuminate and the **fiber port 2** LEDs on FR1 and FR2 should be OFF.

If the **fiber port 1** LED on FR2 does not illuminate, check the Tx and Rx connections on the fiber link. If the problem persists, substitute a known good repeater for FR2 and repeat the procedure. If the problem still persists, check the drop adapter and coaxial link at drop #2. If all this still checks out properly, then you have isolated the problem to faulty fiber cable, and manufacturer's test procedures must be used.

### 5.5.1 Broken Cable Detection and Remedies

Unlike coaxial cable, fiber cable contains physically separate transmit and receive lines. It is possible to lose communications through the Rx line while the Tx line remains intact. A break in the Rx line will deprive the PLC of input data. Under ordinary circumstances, the PLC continues to drive outputs via the intact transmit line. This could lead to outputs turning ON or OFF due to invalid (INPUT STATE: 0) input data. A method to prevent this from happening uses STAT and SENS instructions in ladder logic to detect the loss of input communication and inhibit improper output state changes:

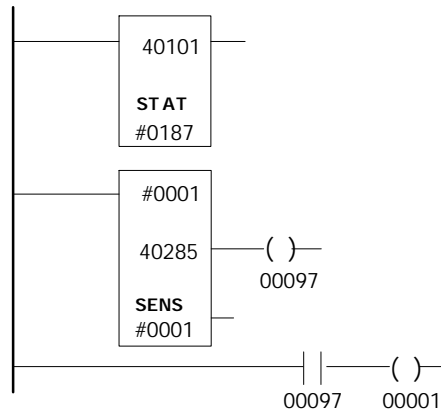

STAT and SENS monitor the I/O status of Drop #2 and inhibit output 00001 if communications are lost. STAT provides access to the system's status, including the status of S908 communications. The status information is stored in a table starting at register 40101 and has a length of 187 words (as shown in the top and bottom nodes of the STAT instruction).

SENS senses the first (communications health) bit (SENS top node value = 1) of the 185th word in the status table (SENS middle node value = 40285). This bit is the communications health for Drop #2 of the S908.

Coil 00001 has been configured as an output in the I/O Map. If the PLC's Rx line is broken, the sensed bit becomes 0 (OFF). The middle node output to coil 00097 is set to 0 (OFF). Coil 00097 controls a normally open relay which, when power is removed, opens the circuits to coil 00001, thus inhibiting this output. The coils can now be used in ladder logic to inhibit specific output writes.

As an alternative, the coil can be used to control a SKP instruction to prevent execution of that portion of the network which would ordinarily output data.

# Appendix A

## RIO Cable Material Suppliers

---

- Comm/Scope, Inc.**  
**Network Cable Division**  
**P.O. Box 1729**  
**1375 Lenoir-Rhyne Blvd.**  
**Hickory, NC 28602**  
Telephone: (800) 982-1708  
(704) 324-2200  
Telex: 802-166  
Fax: (704) 328-3400
  
- Belden Corporation**  
**P.O. Box 1980**  
**Richmond, IN 47374**  
Telephone: (317) 983-5200  
Telex: 499-7255 (domestic)  
94-5989 (international)  
Fax: (317) 983-5294
  
- Times Fiber Communications, Inc.**  
**358 Hall Avenue**  
**P.O. Box 384**  
**Wallingford, CT 06492 0384**  
Telephone: (203) 265-8500  
Fax: (203) 265-8422

**Gilbert Engineering**  
**P.O. Box 23189 5310 West Camelback**  
**Phoenix, Arizona 85063-3189**  
**Glendale, Arizona 85301-7597**  
Telephone: (602) 245-1050  
(800) 528-5567  
Fax: (602) 934-5160  
TWX: 910-951-1380

**LRC Electronics**  
**901 South Avenue**  
**P.O. Box 111**  
**Horseheads, NY 14845**  
Telephone: (607) 739-3844  
Telex: 5101-011-251  
Fax: (607) 739-0106

**Raychem Corporation**  
**300 Constitution Drive**  
**Menlo Park, CA, 94025**  
Telephone: (415) 361-2288  
TWX: 910-373-1728

# Appendix B

## Glossary

---

**amplitude** A measure of the strength of a signal.

**application** A user program.

**armor** A metal wrapping around a coaxial cable used for mechanical protection.

**attenuation** Signal loss through an electrical circuit or conductor.  
(*see also* **signal loss**)

**bandwidth** A range of frequencies.

**baseband** A type of network having a single communications channel. RIO is a baseband communications network.

**bend radius** The radius of the arc along which a cable may be bent

**bit error rate** The number of bits received in an error divided by the total number of bits received.

**braid** A wire mesh used to construct the shield of a coaxial cable.

**bus** A single cable connecting multiple points.

**cable shield** The outer conductor of a coaxial cable used to protect the signal on the cable from noise.

**cable sweep** A test that assures proper network response within a given frequency range.

**carrier detect** A status LED indicating the presence of activity on the network.

**CA TV** Community antenna television.

**center conductor** The center wire in a coaxial cable, usually made of copper or copper clad metal.

**characteristic impedance** The ratio of signal voltage to signal current on a transmission line.

**coaxial cable** A type of transmission line having a center conductor surrounded by an insulator (a dielectric), then an outer shield.

**communications** The transmitting and receiving of messages between nodes (intelligent devices) on the network.

**COMM ACTIVE** A status LED indicating that the modem is communicating.

**COMM ERROR** A status LED indicating that the modem has detected an error in the message.

**COMM READY** A status LED indicating that the modem is able to communicate.

**core** The center region of a coaxial or fiber optic cable through which the signal is transmitted.

**data field** The data portion of a message frame, containing the rudimentary command or data.

**destination address** The part of the RIO message that defines the address of the destination node.

**dispersion** The cause of bandwidth limitations in a fiber optic signal. Dispersion causes a broadening of input pulses along the length of the fiber. Three major types are: *mode dispersion* caused by differential optical path lengths in a multimode fiber; *material dispersion* caused by a differential delay of various wavelengths of light in a waveguide material; and *waveguide dispersion* caused by light traveling in both the core and cladding materials in single-mode fibers.

**drop** An address on the RIO network. (*see also node* )

**drop cable** The cable that runs between a tap in the trunk cable and the connector to the RIO drop adapter at the drop.

**drop loss** The amount of attenuation (signal loss) in the drop cable and the connector—i.e., between the tap and the node.

**dual cable** An RIO network topology in which two cable systems are run from the head processor in a PLC to two different groups of drop adapter nodes. A dual cable topology requires dual RIO comm ports in the RIO processor node and a single RIO comm port in each drop adapter. (*see also redundant cable* )

**fiber** A thin filament of glass. an optical waveguide consisting of a core and a cladding is capable of carrying information in the form of light.

**fiber optics** Light transmission through optical fibers for communications or signaling.

**earth ground** A connection to earth, usually through structural steel or water pipes.

**egress** Signal radiated by the transmission line.

**EMI** Electromagnetic interference, usually caused by inductive devices such as motors. EMI causes noise that can be radiated in the air or conducted through power lines.

**F connector** An industry standard connector for coaxial cable.

**foil** A mylar backed aluminum foil used for shield construction on coaxial cable.

**frame** A message unit, particularly that part between the start delimiter and the end delimiter.

**frame check sequence** A calculated number sent with a message unit and checked by the receiver to assure message integrity.

**graded-index** Fiber design in which the refractive index of the core is lower toward the outside of the fiber core and increases toward the center of the core. It bends the rays inward and allows them to travel faster in the lower index-of-refraction region. This type of fiber provides high bandwidth capabilities.

**ground** A common signal return point from various circuit elements.



**ground block** An RIO network component that may be used as the single point ground for the system.

**HDLC (high level data link control)** The link layer protocol used on an RIO communications network.

**Hot Standby System** A 984 capability in which two identically configured PLCs are connected to the same process via RIO cable systems. One primary PLC controls the process while the other standby constantly monitors the process. If the primary controller fails, the backup controller takes over system control operations.

**impedance** (*see characteristic impedance* )

**ingress** The noise picked up by a transmission line from outside sources.

**input module** A device used to connect field inputs. This module mounts into an I/O housing at a drop/channel location.

**insertion loss** The amount of signal lost through a device.

**LAN (local area network)** A computer network for communication among nodes over a relatively small area (usually less than 10 mi)

**link layer** The RIO communications layer that assures proper message transmission and reception over the network.

**mandrel** The inner section edge of the F connector. As you look into the F connector, the mandrel is the flat edge; the white dielectric must be aligned to the edge of the mandrel.

**mechanical splicing** Joining of two fiber optic cables together by mechanical means—e.g., elastometric splicing—to enable a continuous signal.

**media** Cable system components used to make a network.

**Modbus** A proprietary Modicon protocol for communicating between Modicon systems and host devices—e.g., computers, data access panels

**modem (modulator demodulator)** A device that encodes digital data from a host device to an RF signal transmitted over the network and vice versa.

**multimode fiber** An optical waveguide in which light travels in multiple modes. Typical core/cladding sizes are 50/125  $\mu\text{m}$ , 62.5/125  $\mu\text{m}$ , and 100/140  $\mu\text{m}$ .

**network** A system consisting of the cable media components and the communication nodes.

**node** An intelligent unit or option on the RIO network, either an RIO processor or a drop adapter.

**noise** EMI/RFI generated outside the media by electrical devices and induced on the cable system.

**nondirectional signal** A signal that is allowed to travel in any possible directions or is not restricted to travel in only one direction.

**output module** A device used to connect to field outputs. This module mounts into an I/O housing at a drop/channel location.

**packet** A self-contained block of data with specific protocol parameters, which is transmitted over the media. A message can comprise many packets.

**phase delay distortion** The difference in arrival time between the higher frequency signals and lower frequency signals over distance. Wave form distortion results from the delay in the arrival of the lower frequency signals. Phase delay increases as the length of the cable medium increases.

**preamble** A preset bit pattern at the start of a transmission, allowing other nodes to synchronize with the incoming message.

**protocol** An agreed upon set of parameters known to each node that allows the nodes to communicate with each other.

**pull strength** The maximum allowable torque that may be used to pull a cable through a conduit or enclosure.

**redundant cable** An RIO network topology in which two cable systems are run from the RIO processor in a PLC to the same group of drop adapter nodes. A dual cable topology requires dual RIO comm ports in the RIO processor node and in all the adapters (*see also dual cable* ).

**redundant programmable control** (*see Hot Standby System* )

**remote I/O drop adapter** A node at each remote drop that connects to the coaxial cable system, processes messages from the remote I/O processor, and updates the I/O at the drop. (*see also node* )

**remote I/O head processor** The master node for the RIO network; it processes commands for the PLC, and it sends messages to/receives messages from the adapter nodes on the network.

**repeater** A device that consists of a transmitter and receiver or transceiver, used to amplify a signal to increase signal length.

**response window** A finite waiting time from transmission to an expected reply, preventing the system from being locked out by a nonreplying node.

**retransmission** The resending of a message because transmission error in the message generating node or a failure to receive the message at a receptor node.

**retry** (*see retransmission* )

**retry count** The number of times the RIO processor has had to retransmit a message.

**return loss** The amount of signal reflected back toward the signal origin, expressed in dB down from the original signal. Return loss is caused by impedance mismatch; the high the return loss, the better. (*see also VSWR* )

**RG-6** A standard coaxial cable type, providing good shielding and fair signal loss.

**RG-11** A standard coaxial cable type, providing good shielding and medium to low signal loss.

**RFI (radio frequency interference)** Noise caused by another transmitting device.

**scattering** A property of glass that causes light to deflect from the fiber and contribute to attenuation on the fiber link.

**self terminating F adapter** A device used on a drop cable to provide proper termination in the event that the node is disconnected from the drop cable.

**semirigid cable** A standard coaxial cable with very low loss and maximum shielding over the maximum trunk cable distance.

**sequence number** Part of the RIO message sent over the medium so that the nodes can track packet numbers in the event that a packet retransmission becomes necessary.

**shield** The outer conductor of a coaxial cable that protects the message transmission on the cable from noise.

**shield effectiveness** Measured in dB—the higher the value, the better the cable shield.

**signal loss attenuation** The amount of signal lost through media devices. (*see also* )

**spectrum analyzer** A device used to test the medium's ability to transmit within a frequency range. It shows signal amplitude on the y axis and frequency measurement on the x axis.

**star coupler** Optical component that allows emulation of a bus topology in fiber optic systems.

**start frame delimiter** A preset octet pattern marking the start of the message packet.

**sweep generator** A test device for checking the amplitude integrity of a medium over the bandwidth of RIO signals. It generates a user specified output signal at a user specified frequency.

**tap** A passive device used to isolate a node from the trunk cable. It allows only a portion of the signal to be transmitted through a port on the tap.

**tap insertion loss** The amount of signal loss in the trunk caused by inserting a tap.

**tap terminator** A standard terminator for open ports on a tap.

**TDR (time domain reflectometer)** A test device for measuring the integrity of a medium regarding impedance mismatch and connections.

**terminator** A piece of hardware containing a 75  $\Omega$  resistor, used at the ends of the trunk cable, at each node, and at each tap outlet to match the characteristic impedance of the cable. (*see also* **characteristic impedance** )

**through loss** The signal loss through a device caused by physical insertion of the device in the trunk cable. (*see also* **insertion loss** )

**topology** The complete media specification. The topology should be mapped into a log with all installation details for future reference.

**I/O map** A table in the PLC's user memory that directs I/O data to the proper drop/channel and I/O module.

**transfer impedance** A measure of cable's ability to reject noise. The lower the number, the better the cable.

**trunk cable** The main cable running from the RIO processor upon which taps are installed, permitting the drop adapters to connect to the cable system.

**trunk terminator** a precision terminator used at the two ends of the trunk cable. (*see also* **terminator** )

**velocity of propagation** The speed of the signal in the cable, expressed as a percentage of the speed of light in free space.

**VSWR (voltage standing wave ratio)** The measure of the signal reflected back from a transmitted signal. Lower ratios indicate better impedance match and cause less signal to be reflected back at the transmitting source. (*see also return loss* )

**wavelength** The distance between the same point on adjacent waves.

**zero crossing** The condition when the wave form crosses 0 V, either on a voltage rising or on a voltage falling. (*see also phase continuous signaling* )

